



Canadian Grain
Commission

Commission canadienne
des grains



Sampling Systems Handbook and Approval Guide

CGC Industry Services ISO 9001:2008

Last revision: November 1, 2013

Table of Contents

Table of Contents	2
Chapter 1	4
General information	4
1.1 Purpose	4
1.2 Authority	4
1.3 Responsibilities	5
1.4 Definitions	6
Chapter 2	8
Automatic sampling systems for licensed grain handling facilities.....	8
2.1 Overview	8
2.2 Equipment requirements	8
2.210 Intended use	11
2.211 Marking	11
2.212 Repeatability	11
2.213 Speed of traverse.....	11
2.214 Power, air, and hydraulic sources	11
2.215 Controls.....	12
2.216 Enclosure and access	12
2.217 Sample collector openings	12
2.218 Sample return.....	13
2.219 Sample delivery lines	13
2.220 Sampler delivery access	13
2.221 Clearing between lots.....	14
2.222 Location and installation.....	14
2.223 Segregation of samples	15
2.224 Divider installation	15
2.225 Timer installation and use	16
2.226 Blending limitations	17
2.227 Integrity of grain lots.....	17
2.3 Verification and approval process	17
2.4 Security of Sampling System	18
2.5 Maintenance.....	18
2.6 Monitoring and oversight.....	19
Chapter 3	20
Conditionally approved automatic sampling systems for specific CGC programs	20
3.1 Overview	20
3.2 Equipment.....	20
Chapter 4	23
Manual sampling.....	23
4.1 Manual stream sampling	23

4.11 Determining sampling frequency when stream sampling	24
4.2 Manual sampling static lots	25
4.21 Approved triers by crop type for grain	27
4.22 Requirements for probing sacked grain	28
4.23 Procedure for sampling horizontally – double sleeve trier	28
4.24 Procedure for sampling vertically – double sleeve trier.....	28
4.25 Procedure for sampling - Nobbe trier	29
4.26 Determining sampling intensity for static lots (bags).....	30
4.27 Sampling Intensities of Grain Stored in Totes	30
Chapter 5	32
CGC Approved Sample Dividing Equipment	32
Chapter 6	33
Contact information.....	33

Chapter 1

General information

1.1 Purpose

The Sampling Systems Handbook and Approval Guide outline the policies and procedures of the Canadian Grain Commission (CGC) for automatic mechanical sampling systems used for inward receipt, and outward discharge of grain at licensed terminal elevators. It includes the requirements for the installation, examination, testing, approval, and ongoing monitoring and oversight of these systems. It also includes information on CGC approved methods of sampling for the Accredited Container Sampling Program (ACSP) and the Certified Container Sampling Program (CCSP). A section on manual sampling is also included, which may be used **at the discretion of the CGC** when a lot of grain cannot be sampled by mechanical means.

A grain handling facility mandated or requesting CGC inspection services must install CGC-approved automatic sampling equipment to sample grain in the facility.

This guide is intended for use by CGC staff, producers, and members of the grain trade, and supersedes any previous CGC sampling directives. It contains the following chapters:

Chapter 1: General Information

Describes the purpose of the document, the authority and responsibilities of interested parties, and relevant definitions as they apply to this Guide.

Chapter 2: Automatic Sampling Systems for Licensed Grain Handling Facilities

Describes equipment, verification processes, security, maintenance, and monitoring and oversight of automatic sampling systems.

Chapter 3: Conditionally Approved Automatic Sampling Systems for Specific CGC Programs

Describes the equipment and programs to which these samplers may be approved.

Chapter 4: CGC Approved Manual Sampling Methods

Describes various manual sampling methods used for static and flowing grain.

Chapter 5: CGC Approved Sample Dividing Equipment

Describes the equipment and procedures used to divide composite samples into smaller representative portions.

Chapter 6: Contact Information

1.2 Authority

This manual has been prepared under the authority of the Canada Grain Act and the Canada Grain Regulations.

<http://www.grainscanada.gc.ca/legislation-legislation/act-loi/cga-lgc-eng.htm>

<http://www.grainscanada.gc.ca/legislation-legislation/regulation-reglement/cgrm-mrgc-eng.htm>

1.3 Responsibilities

The CGC inspects, approves and oversees the operation of all automatic sampling systems at terminal elevators used to draw official samples for cargo destined for direct export. In addition, the CGC's responsibilities include an oversight role for inward sampler and delivery systems used for receipt of grain at licensed terminal elevators. These systems will be subject to regular monitoring and oversight protocols established by the CGC. The protocols for automatic sampling systems used to collect these samples will be determined upon the sampling systems' installation location and use within each licensed grain handling facility.

The operator of the grain handling facility that owns, leases, or operates the automatic sampling system is responsible to:

1. Provide a written request for CGC approval of a sampling system.
2. Install all equipment subject to CGC approval as prescribed by the manufacturer.
3. Cooperate with the CGC for the examination and testing of sampling systems.
4. Provide all necessary repairs, maintenance, and environmental considerations specified by the CGC and the manufacturer.
5. Provide written notification to the CGC of any ongoing problems that may be occurring with any approved sampling systems.
6. Keep maintenance logs specific to CGC approved sampling systems and make them available for review by CGC staff when requested.
7. Provide written notification to the CGC if alterations to the system are planned, including any physical changes to equipment or facility that may alter the grain flow to, through, or leaving the sampling system.
8. Provide written notification to the CGC if the sampling system will no longer be used to obtain official samples.

Sampling systems used to draw official samples for direct export and inward receipt of grain at terminal elevators must be operated in accordance with the Sampling Systems Handbook and Approval Guide.

1.4 Definitions

The definitions given here are used throughout this Guide.

1. **Alteration**
Modifications or changes made to the sampling system after the system was last tested by the CGC. This would include changes to sampler position, parts, speed, wiring, dust collection, etc. and also include changes to the grain handling system that may affect the sampling system, such as an increase in grain flow, change in belt speed, and use of new shipping bins.
2. **Approval**
The written approval issued by the CGC to licensed grain handling facilities to operate new automatic sampling systems within their facilities. These sampling systems have been evaluated and found to meet the requirements as described in this Guide.
3. **Auxiliary controls**
Device that duplicates or bypasses the operating controls or interrupts the exclusive CGC use of the sampling device.
4. **Cancellation**
The permanent withdrawal of CGC approval of a licensed grain handling facilities' sampling system. In order for a cancelled approval to be reinstated, the facility must submit a new approval request, and the sampling system must undergo all necessary examinations and tests.
5. **Commodities**
Grain, grain products, or screenings found in a licensed grain handling facility.
6. **Composite sample**
A sample which is comprised of the total number of primary samples taken from a lot of grain.
It is formed by combining and mixing all primary samples together from one specific lot of grain.
7. **Lockout control**
Device used to disconnect the main power supply to all the sampling equipment and bring the entire sampling system to a zero energy state.
8. **Official sample**
A sample taken from a parcel of grain by a person authorized by the Commission.
9. **Operating controls**
Controls used by CGC personnel for the normal operation of the sampling system. These would include on/off control panel switches, timers, sampler indicator lights, and pneumatic sample delivery system indicator lights.
10. **Primary sample**
A portion of sample taken from a lot of grain during one single sampling action.
11. **Primary sampler**
Main sample collector installed at an inward or outward inspection sampling point in a licensed facility.
12. **Sample divider**
The mechanical or gravitational divider used to reduce the size of the sample obtained by the primary sampler.

13. Sampling action

The act of capturing grain from the lot; e.g. by one single entry and withdrawal of the double sleeve trier, or one scooping action of grain flowing on a belt, or one single pass of an automatic cross stream sampler.

14. Suspension

A written confirmation by the CGC withdrawing the use of a sampler and/or delivery system. A formal suspension may not be required if the sampler and/or delivery system problems are corrected immediately or before the sampler is used officially.

15. Unofficial sample

A sample taken from a parcel of grain that does not meet the definition of an “official sample” as defined above.

Chapter 2

Automatic sampling systems for licensed grain handling facilities

2.1 Overview

Automatic sampling systems used to collect official samples for CGC official inspection purposes and inward receipt of grain at licensed terminal elevators must meet the requirements as defined in this Guide.

In general, the CGC will give approval only to automatic sampling systems that extract a complete and proportional cross-section of the grain stream (both height and width), proportionally reduce the sample size, and deliver the sample to the inspection area. Samplers of this type are commonly referred to as cross-stream diverter-type samplers. The dividers and the delivery system must conform to manufacturer specifications and must be constructed of the industrial durability required to operate in the environment where the system is located.

The CGC must retain operational control or have access to the operational control of automatic samplers and the authority to accept or reject the use of those devices. As proprietors of the sampling systems, grain handling facilities must be aware of their responsibilities to obtain and maintain CGC approval of their sampling systems.

2.2 Equipment requirements

CGC approval for any new sampling concepts will be based on the ability of the proposed sampling system to extract a two dimensional (height and width) section of the grain stream, proportionally reduce the sample size, and deliver the sample to the inspection area.

Arc-path samplers may be approved for official inspection purposes, provided that the cutter opening exposes a minimum of 1.9 cm (0.75 inches), measured perpendicular to the grain stream, as the cutter enters and exits the grain stream.

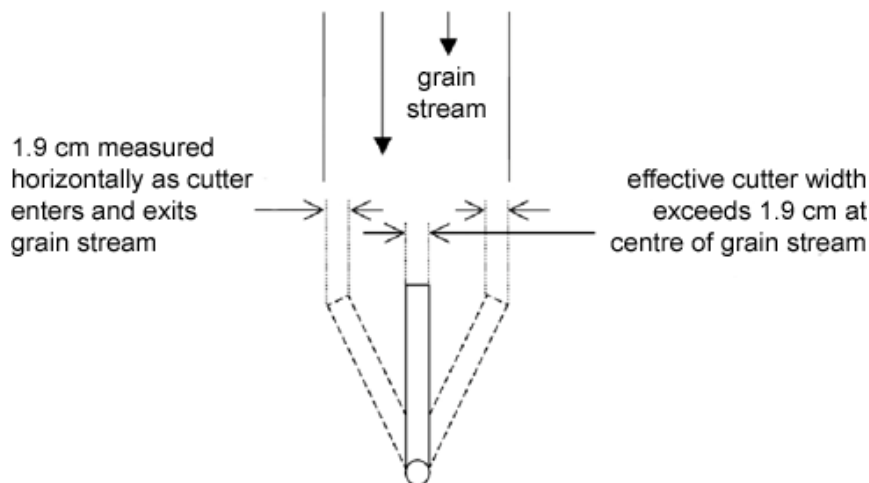

Cutter opening requirement for arc-path cross-stream samplers. The line drawing is showing the cutter opening measuring at least 1.9 cm (0.75 inches) as it enters the grain stream, when it is at the centre of the grain stream, and as it exits the grain stream.

Front view of cutter – belt end

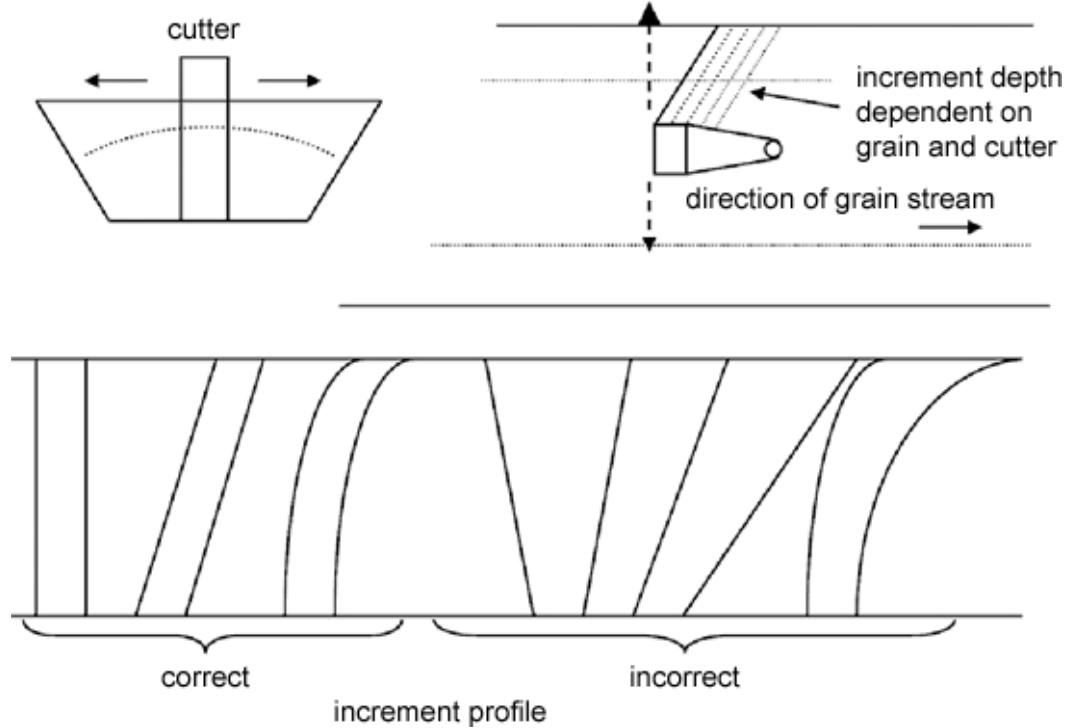

Cross-stream sampler cutter path. The line drawing is showing the requirements for sampling using a cross-stream sampler. The diagram shows the sampler cutter trajectory and direction, and illustrates both a correct sample increment and an incorrect sample increment. The diagram shows that the width of the increment must be the same, regardless of where it is taken in the grain flow.

Arc-path cross-stream samplers

An arc-path cross-stream sampler is defined as a sampler where the cutter rotates from a centre point and traverses the grain stream by following an arced path. These may be either flowing stream samplers or falling stream samplers.

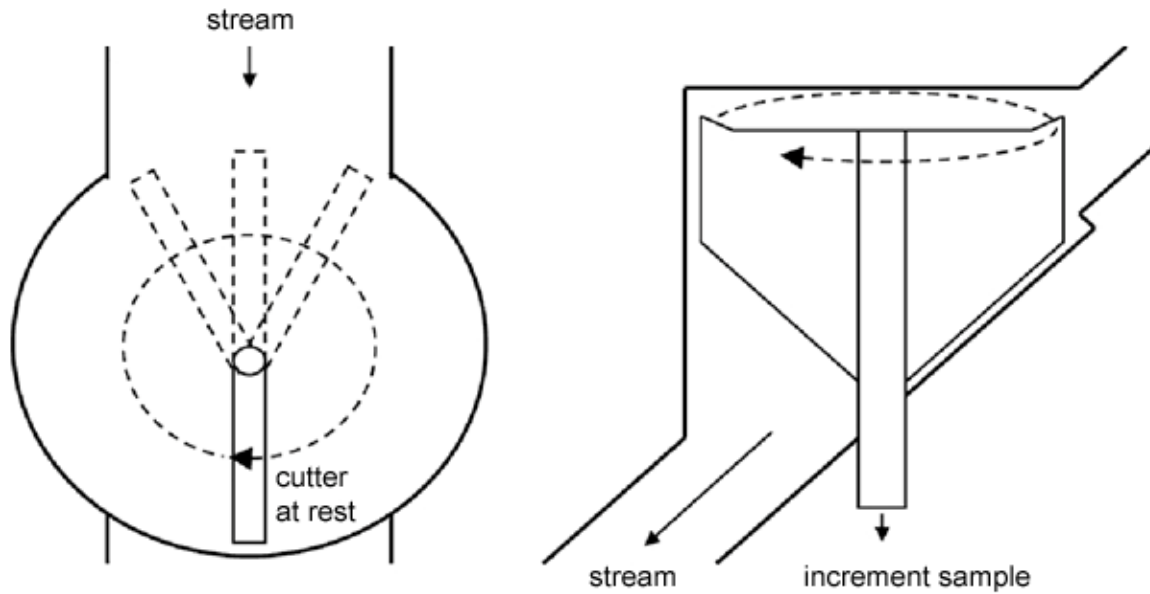

Flowing stream. The line drawing is showing a top view and a side view of the flowing stream type of arc-path cross-stream sampler. The diagram shows the direction of the grain stream, the sampler cutter trajectory, and the direction of the increment sample.

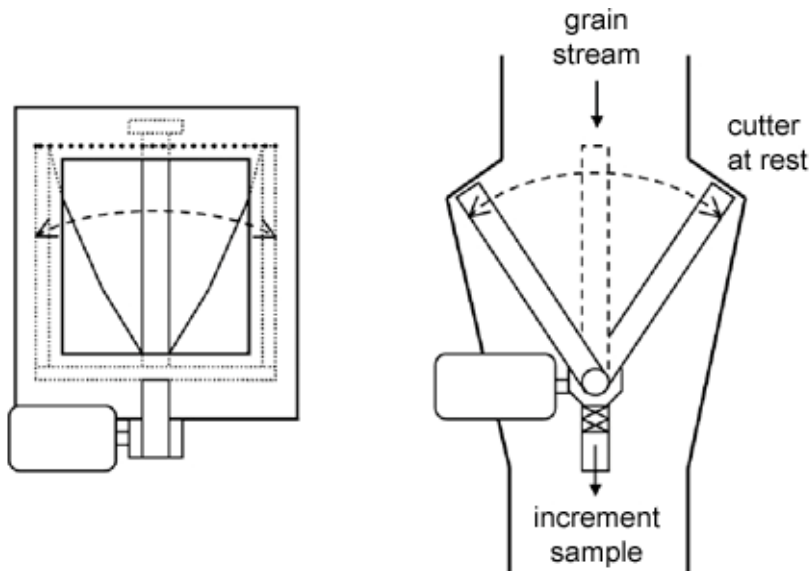

Falling stream. The line drawing is showing a top view and a side view of the falling stream type of arc-path cross-stream sampler. The diagram shows the direction of the grain stream, the sampler cutter trajectory, and the direction of the increment sample.

2.210 Intended use

The design, composition, and construction of a sampling system and its associated equipment must suit the environment, the installation location, and the intended official use of the sampling system. The device must be able to withstand normal operation within the facility without loss of reliability or accuracy. Under normal operation, any moving parts must remain operable and any adjustments must remain reasonably constant.

2.211 Marking

The primary sampler and associated divider or pneumatic components must be permanently marked to show the manufacturer, model, and serial numbers. The rated maximum throughput capacity must also be marked on the device or be readily available based on the model number.

2.212 Repeatability

The overall dimension of the sample entry and sample cutter must be adequate for the volume and velocity of the grain being sampled, and must allow:

1. All grain presented for sampling to be accepted as the collection opening passes through the grain stream
2. The sample cutter to deliver the entire collected sample to the divider for reduction or to the final sample collection site

When collecting official samples:

The rate of grain flow past the sampler should not be less than 25% of the rated maximum capacity of the grain elevation/conveying system.

All sampling systems installed within a grain handling facility must provide a similar quantity of sample when used for the same purpose. The quantity of sample delivered must be within 10% of any other sampling system when sampling the same type and quantity of grain.

2.213 Speed of traverse

Any non-programmable speed setting must be set to maximize the efficiency and effectiveness of the sampling system. The traverse speed of the sample cutter across the grain stream must be set at 0.47 – 0.51 metre per second (18 – 20 inches per second) and at an even rate of acceleration.

2.214 Power, air, and hydraulic sources

Electrical power sources for the operation of a sampler and any associated equipment must be maintained at a constant voltage to ensure the smooth and unaffected operation of the equipment. Air or hydraulic sources for the operation of a sampler and any associated equipment must be maintained at a constant and uniform pressure to ensure the smooth and unaffected operation of the equipment. If the operation of any equipment attached to the same air or hydraulic supply affects the operation of the sampling system, a separate air or hydraulic supply will be required.

2.215 Controls

During the operation of a sampling system for official inspection, the control of the timer and resets must be under the direction of the CGC staff on site or be readily available to them. If a grain flow indicator is required to verify grain flow rates, it must be made available. Equipment controls must be marked conspicuously and be within viewing range of the CGC staff.

2.216 Enclosure and access

All sampling components must be maintained within protective enclosures. The sampling system must have strategically located access points for inspections. The locations must allow for ready and easy examination of the sampler components, including the sample cutter openings, motion activation equipment, and dust seals.

2.217 Sample collector openings

The opening of a sampler cutter must be at least 1.9 cm (0.75 inches) wide, measured horizontally to the grain stream. The opening may be reinforced with narrow support braces to provide structural support and eliminate any distortions to the opening.

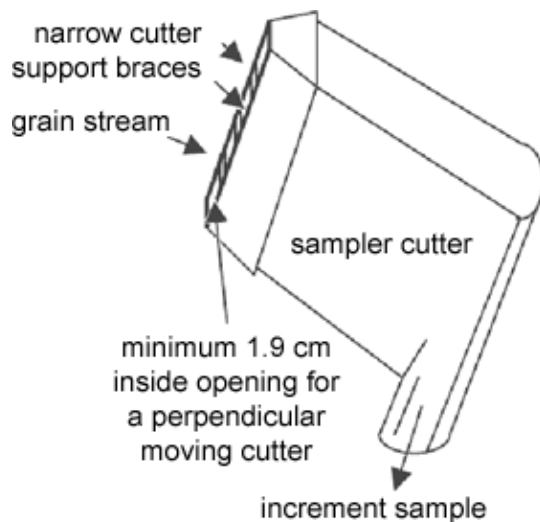

The line drawing is showing a sampler cutter in which the opening is reinforced with narrow support braces. The diagram shows the direction of grain stream and increment sample.

2.218 Sample return

Where the sampling system is installed after a weighing system in a shipping installation or before a weighing system in a receiving installation, means must be provided to return the surplus sample back to the source grain lot. Where miniature bucket elevators, screw conveyers, or drag conveyers are used to move the surplus sample, they must be adequately sized to prevent a backlog of grain in the system.

Either the return line for the sample must be to a neutral air pressure location, or automatic means must be in place to prevent any dust or lightweight material from being pressured back into the sample divider or from being vacuumed or vented out of the sample divider.

2.219 Sample delivery lines

Sample delivery lines from the sample divider to the inspection area must follow the most direct route to the inspection area with as few bends as possible. In particular:

1. Delivery lines must not have a turn radius greater 90 degrees and must be laid vertically or horizontally as much as possible.
2. The delivery conduit must be cut squarely and the inside edges honed to remove any roughness or burrs.
3. Conduit for negative or positive pressures must be connected with an airtight coupling.
4. An electrical path must be maintained over the entire delivery system with suitable grounding points to discharge any static build up. (It is recommended that sample delivery lines be of metal conduit construction, aluminum straight pipe, and stainless steel elbows.)
5. The air intake on pneumatic systems must be equipped with a suitable cover to stop unwanted material from being introduced into the official sample. The cover must be designed to accommodate security seals and also removable to allow for inspection and any necessary testing.

2.220 Sampler delivery access

A sampler delivery system must have an access point as close to the primary sampler as possible and after any sample divider. The purpose of this requirement is to allow the CGC to evaluate the delivery lines by introducing CGC control samples. These access points must have means to provide security seals.

2.221 Clearing between lots

The entire sampling system, including delivery lines, must be self-clearing to prevent sample contamination from one lot of grain to another while in use.

2.222 Location and installation

The location selected for a proposed sampling system must meet the requirements of the CGC. Any nearby equipment must not adversely affect the operation of the sampler or delay its operation in any manner. Lighting in the area of the sampler must be sufficiently intense (approximately 100 lux) and preferably permanently installed in order to allow the visual inspections of the sampling system.

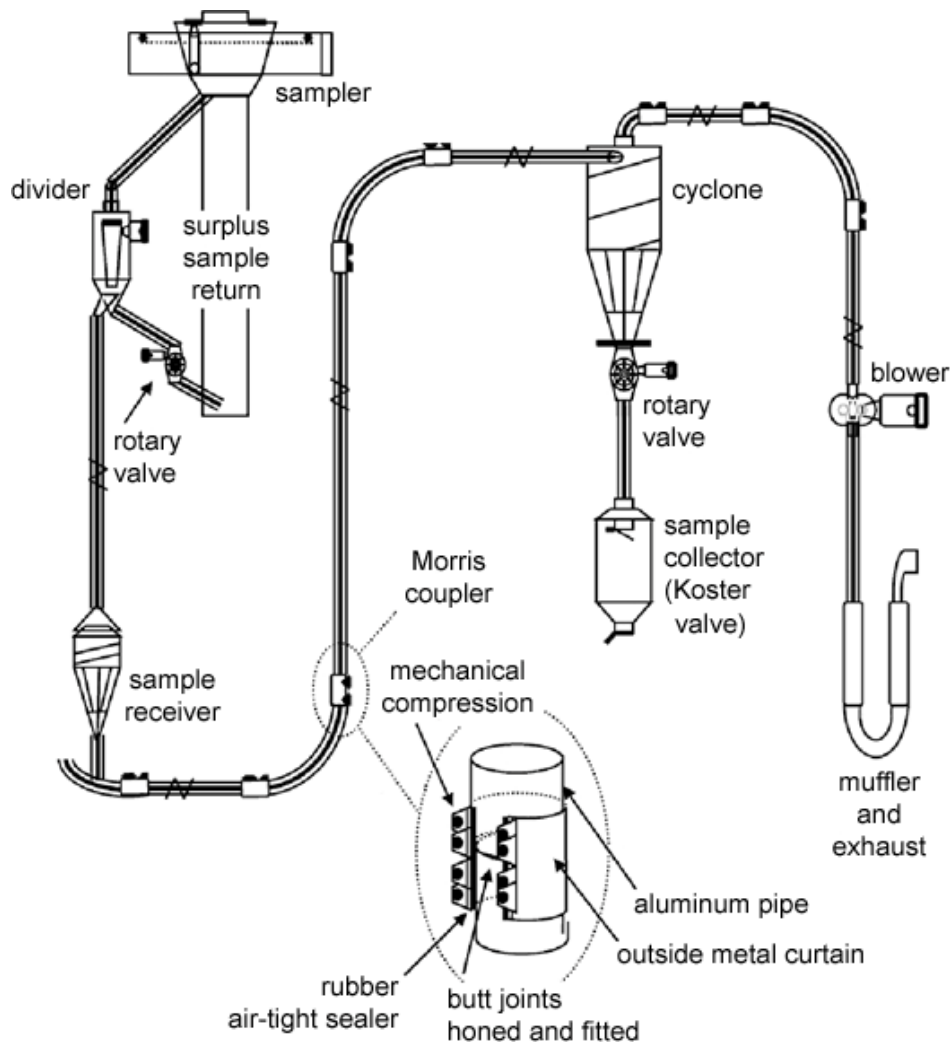

Basic automatic sampling system configuration. The line drawing is showing the path a sample takes from the sampler through to the sample collector (Koster valve). The diagram includes an expanded schematic of a Morris coupler. Morris couplers are used at various points along the delivery lines.

2.223 Segregation of samples

This section describes how to locate samplers and segregate samples in such a way as to ensure that the sample is representative of the grain lot.

1. On inward (receiving) sampling systems, the sampler must be located before or immediately after the initial elevation. The sample is considered representative only after the entire lot of grain being sampled has passed the sampler.
2. On outward (shipping) sampling systems, the sampler must be located after the final elevation and as close as practical to the end of the loading spout. The sample is considered representative only after the entire lot of grain being sampled has passed the sampler.
3. Samplers located in spouts must not come after a vertical drop of more than 15 metres or be within 0.6 metre of any bends in the spouting.
4. Before sampling grain to railcars, the sample grain delivery system must be purged with the same grain and quality. The purge must be to the furthest return-to-house point in the shipping system. The grain delivery system must also be purged in the same way if the elevator operator changes the grade or grain to be sampled.
5. Outward samplers used for loading railcars must be installed or operate in such a way that the railcar into which the sampled grain is loaded can be identified for each sample.
6. Where the sampler is located above the weighing system, or below the scale but before shipping or pre-weigh bins, there must be automated means available for CGC staff, such as bin or hopper empty sensors, to identify that the grain being sampled has been delivered to the intended conveyance.

2.224 Divider installation

The divider associated with a sampler must be installed in accordance with the manufacturer's specifications and be reasonably close to the main sampler. A gravity or automatic sample divider must be adequately sized to reduce the quantity of sample from the primary sampler without backing up. Sample divider openings used to select the final sample must be at least 1.9 cm (0.75 inches) measured horizontally to the primary sampled grain stream.

The divider installation site must be free of hazards, have adequate space for inspecting the device, and be sufficiently clean from dust, spilled grain, and refuse. Lighting in the area of the divider must be sufficiently intense (approximately 100 lux) and preferably permanently installed. Dividers may be of the swing arm type or the rotary type.

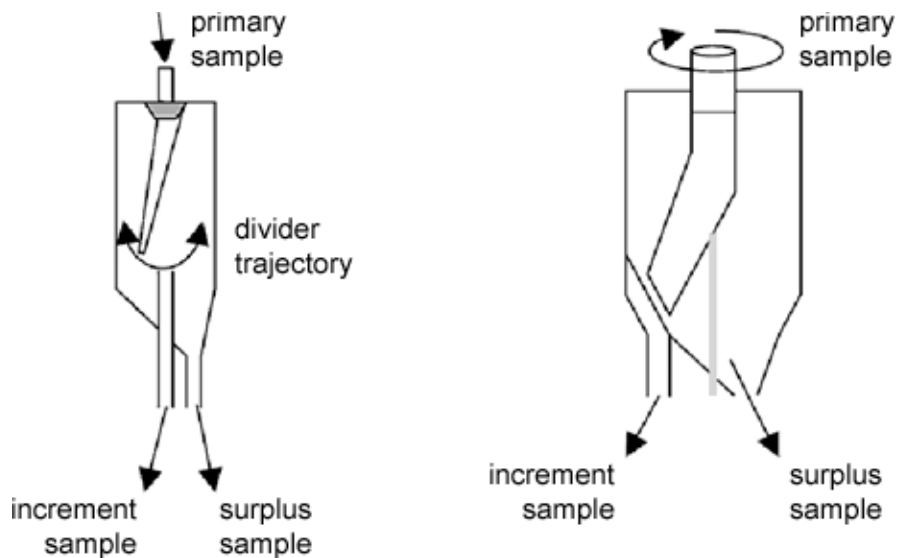

The line drawing is showing a swing arm divider and a rotary divider. In both diagrams the path of the increment sample and the path of the surplus sample are shown.

2.225 Timer installation and use

Sampler timers may be either analog or digital, and must have a maximum 1-second dial or timer interval setting. A sampler timer must be accurate to within ± 1 second of the cycle time.

At facilities where the timers reside in the programmable logic controller (PLC) of the facility, access to the programming must be made available on request. The facility must bring any adjustment to the timing of the sampler to the attention of the CGC inspector on site prior to making the change.

When loading or unloading railcars or trucks, the timer of a cross-stream sampler must be set to an interval **not greater than 20 seconds**. The divider reduction rate and the sampler timer interval must be set to collect a sample quantity representing between 0.0025 percent and 0.0075 percent of the lot being sampled. For example; on a 90 tonne railcar, between 2.25-6.75kg of sample must be collected.

When loading or unloading vessels or barges, the timer of a cross-stream sampler must be set to an interval **not greater than 45 seconds**. The divider reduction rate and the sampler timer interval must be set to collect a sample quantity representing between 0.0005 percent and 0.001 percent of the lot being sampled. For example; on a 2000 tonne increment, between 10 to 20kg of sample must be collected.

When loading railcars where the sampler is below the weighing system, it is permitted to interlock the sampler with a scale draft counter if the following is met:

Where the draft of the bulk weighing system is less than 8 tonnes, the sampler may be timed to traverse at approximately the middle of the draft discharge or it may traverse at a random interval during the discharge. The random interval must not be controlled by an operator and must ensure that the sampler traverses during the period when grain is flowing.

It is also acceptable to have the sampler traverse the grain stream based on the time during which grain is actually flowing past the sampler in a spout. To accomplish this, a flow detector is

installed immediately before or after the sampler and is integrated with the sampler control. The flow sensor activates the sample interval timer when product is flowing in the spout and stops the time when there is no flow. When flow is detected again, the interval timer resumes from the point where it stopped.

For example, if the sample interval is 20 seconds and flow stops when the elapsed time since the sampler last traversed is 16 seconds, the sampler traverses when flow has resumed for 4 seconds.

2.226 Blending limitations

Any blending of grain must be completed in an even and uniform manner prior to the grain reaching the sampler.

2.227 Integrity of grain lots

Means must be provided to prevent the addition of grain or other commodities to the grain stream, or the removal of any portion of the sampled grain, after it has passed the sampler. Feeder spouts or diversion spouts after the sampler must be sealable with CGC security seals, keyed locks, or positive electronic means under the direction of the CGC. If, during official CGC inspections, security means are found to be missing or to have been tampered with, the shipment or lot will be rendered non-representative.

The sampling, weighing, and delivery systems must not be manipulated, operated, or circumvented in any manner intended to purposefully influence, degrade, or bias the sample, any part of the sample, or the lot of grain the sample represents.

2.3 Verification and approval process

Prior to being put into service, any new or modified sampling unit must be examined by CGC Industry Services.

Before requesting CGC approval, the facility should compare belt samples or spout samples (obtained using standard manual sampling methods or an acceptable alternative) with the mechanically obtained sample from the same lot, in order to prove likeness and quality preservation through the system. They should also test the delivery lines to ensure they are operating in accordance with the conditions outlined in this Guide.

Before granting approval, CGC Industry Services examines the sampling system to confirm all the requirements outlined in this Guide are satisfied. This evaluation is a series of three steps, all of which need to be completed in their entirety prior to approval being granted. CGC employees will coordinate the timing of this process with the grain handling facility.

The grain handling facility will be required to give access, and assist in any evaluations as determined by the CGC. All results of any testing conducted will be made available to the facility upon request.

Step 1: Complete a Sampler Condition and Efficiency Check. This process involves examining all the sampling equipment to ensure the installation meets the requirements as per manufacturers' specifications and those identified in this Guide.

Step 2: Complete a Delivery System Check. In a delivery system check, three samples of known quality and quantity per grain group are introduced into the delivery system as close to the primary sampler as possible. The samples are collected and analyzed for quantity and quality. A total of six samples are used to evaluate the effective operation of the delivery lines. The results of this test are analysed and used to identify any potential areas of concern in the operation of the delivery system. It is at the discretion of the CGC to accept or reject the results of this process.

Step 3: Complete an Operational Verification. This process consists of a visual and operational confirmation that the sampling system operates as generally described and delivers a sample conforming to the requirements of this Guide over a period of time to be determined by the CGC. The verification may also include a comparison to manually obtained samples or to samples obtained by another automatic sampler to ensure the sample resembles the properties of the grain being sampled.

Sampling systems must meet all the examination requirements in order to be approved. Basis the results of the evaluations described above, the CGC will issue a letter of notification indicating the status of the sampling system to the grain handling facility. Results of any testing conducted by the CGC will be made available to the grain handling facility upon request.

2.4 Security of Sampling System

Means must be provided to apply CGC security seals to any access points as determined by the CGC. For example, any inspection doors located on the sampler and divider, or on certain delivery lines to ensure the integrity of the system is maintained and verifiable as deemed necessary. When any security seals are breached by grain handling facility staff as a result of maintenance, or any other cause, the CGC must be notified immediately so security seals may be reapplied and documented as required. Any security seals found not to be intact may result in a temporary suspension of the sampling system until the details of the security seal breach can be investigated.

2.5 Maintenance

It is the responsibility of the grain handling facility to install and maintain all CGC approved sampling systems as prescribed by the manufacturer and in accordance with this Guide. The grain handling facility must provide all necessary repairs, maintenance, and environmental considerations specified by the CGC and the manufacturer. When alterations to the system are planned, or unexpectedly arise, the elevator must notify the CGC and provide written details prior to initiating any change to the system. The facility is responsible to keep a “maintenance log” on each CGC approved sampling system, to be made available for review on request. Any ongoing sampling system problems that are being experienced by the grain handling facility operators are to be reported to the CGC. Any CGC security seals that are breached when performing any maintenance function will need to be reported. When any alterations are made to any sampling system or components thereof, the CGC may require the system be re-evaluated to ensure its continued compliance to this Guide. At the discretion of the CGC, this may require a detailed evaluation of the entire system.

2.6 Monitoring and oversight

The CGC approves and oversees the operation of all automatic sampling systems used to draw official samples on outward discharge at licensed terminal grain handling facilities. In addition, the CGC's responsibilities include an oversight role for inward sampler and delivery systems used for receipt of grain at licensed terminal elevators. These systems will be subject to regular monitoring and oversight protocols established by the CGC. The protocols for automatic sampling systems used to collect these samples will be determined upon the sampling systems' installation location and use within each licensed grain handling facility. The monitoring and oversight protocols for CGC approved automatic samplers used for inward receipt and outward discharge from licensed terminals is as follows:

Inward receipt into licensed terminal elevators

On a 3 month cycle, the CGC will conduct visual "walk-thru" inspections, which will include; and not be limited to, checking the entire system for any leaks, diversions, intact security seals, equipment verifications, and general condition and operation. Terminal elevator sampling system maintenance records will be reviewed as required, verifying that the sampling system is being maintained and operating as described in this Guide.

On a 12 month cycle, the CGC will conduct a complete "Verification and Approval Process" (see section 2.3) of the entire sampling system to ensure its continued conformance to the requirements outlined in this Guide.

Samplers that are considered by the CGC to be in use "seasonally" will be evaluated prior to commencement of the season. The requirements for CGC approved automatic sampling systems that are only used "occasionally" will be determined on a case by case basis at the discretion of the CGC.

Note: At the discretion of the CGC, any approved sampling system that is suspected to be operating with questionable accuracy may be subject to an in-depth review prior to the 12 month anniversary review period.

Any system found not to be in compliance with this Guide will result in written notification to the terminal elevator operator for the necessary remedial action, including an expected timeframe in which to address the non-compliance(s).

Outward discharge from a licensed terminal elevator

On a 36 month cycle, the CGC will conduct a complete "Verification and Approval Process" (see section 2.3) of the entire sampling system to ensure its continued conformance to the requirements outlined in this handbook.

CGC staff onsite will visually monitor the sampling system daily when in use. A visual check of the samplers, dividers, and delivery systems will be made for any leaks, diversions, intact security seals, and general condition and operation.

Note: At the discretion of the CGC, any approved sampling system that is suspected to be operating with questionable accuracy may be subject to an in-depth review prior to the 36 month anniversary period.

Any system found not to be in compliance with this Guide will result in written notification to the terminal elevator operator for the necessary remedial action, including an expected timeframe in which to address the non-compliance(s).

Chapter 3

Conditionally approved automatic sampling systems for specific CGC programs

3.1 Overview

Strip auger samplers or point type samplers are considered by the CGC to be non-conforming as they do not extract a complete and proportional cross-section (both height and width) of the grain stream.

However; these types of samplers may be considered if they are being used by licensed grain handling facilities operating under specific CGC programs.

Accredited Container Sampler Program (ACSP)

This program allows grain companies to obtain official CGC inspection and certification for their container shipments based on a sample taken by a CGC accredited third party. Any automatic sampling system used by these third parties to acquire samples must conform to the requirements of a “conditional approved automatic sampler”, and be approved by the CGC.

For more information on this program, please visit our website at:

<http://www.grainscanada.gc.ca/pva-vpa/container-contenant/acsp-peac-eng.htm>

Certified Container Sampling Program (CCSP)

This program allows grain and transloading companies to take samples at their facilities and submit them to the CGC for inspection and certification. The certificate issued under this program is the “Certified Submitted Sample Certificate” which states that “*The lot or consignment identified above has been sampled by a shipper or loading facility officially recognized as operating under a Canadian Grain Commission certified sampling program.*”

For more information on this program, visit our website at:

<http://www.grainscanada.gc.ca/pva-vpa/container-contenant/ccsp-pecc-eng.htm>

3.2 Equipment

At the discretion of the CGC, a “Conditionally Approved” sampling system may be used to sample grain for either the ACSP or CCSP program provided that:

1. The sampled grain, either bulk or bagged is destined for shipment in a container.
2. The grain being sampled has been cleaned and does not contain dockage material.
3. The sampling system has been reviewed and authorized by the CGC.
4. The sampling system is used and maintained in the manner deemed suitable by the CGC.

The following criteria will be used by the CGC in reviewing and authorizing sampling systems for these programs:

1. The sampling tube may be either installed permanently in the grain stream or the tube may extend into the grain stream intermittently.
2. Where the sampling tube extends into the grain, the tube must extend to at least 75% of diameter of the grain stream.
3. The combined length of the sampler tube opening on the sampling tube must be at least 55% of the probe length.
4. One sampling tube opening must be within 0.75 inches of the spout wall where the product is flowing.
5. The dimensions of the sampling tube openings must be at least 19 mm (0.75 inches) wide and 88.9 mm (3.5 inches) long and be in a uniform pattern along the entire length of the tube.
6. Automatic samplers must have an adjustable timer. Sampler timers may be either analog or digital, and must have a maximum 1-second dial or timer interval setting.
7. Sampling intervals will be determined on a case by case basis, to ensure adequate sampling intensities and frequencies are being achieved.

Note: any deviations from these criteria will be considered on a case by case basis.

Some examples of automatic samplers that may be considered for use under this program are:

Strip auger samplers

The following diagrams show 4 different strip auger sampler installations, each collecting an increment sample at a specific point.

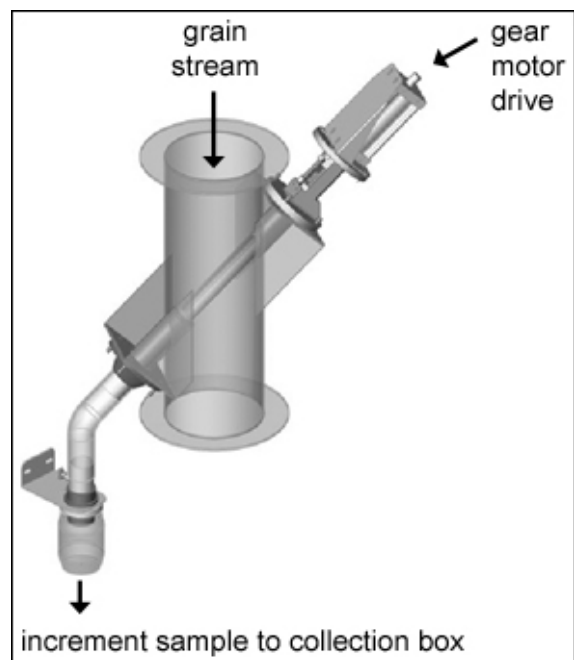
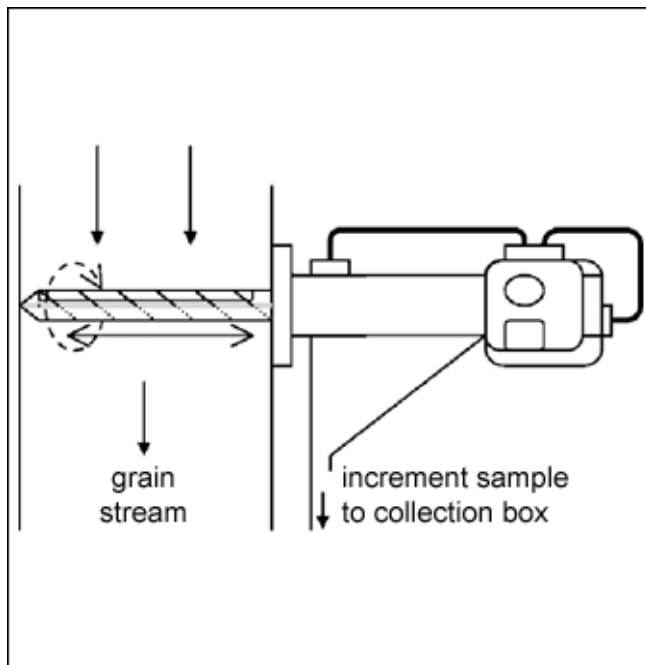

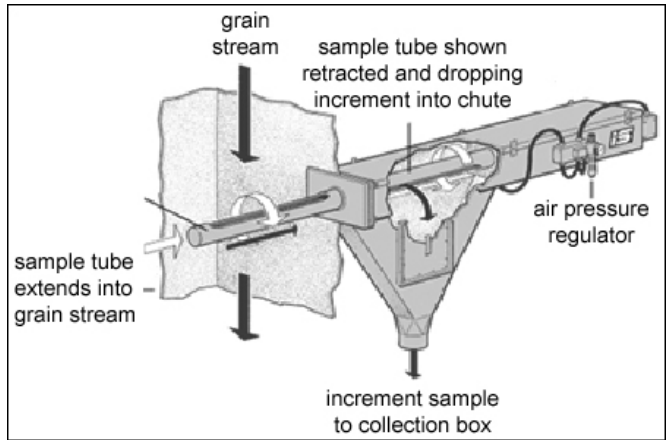
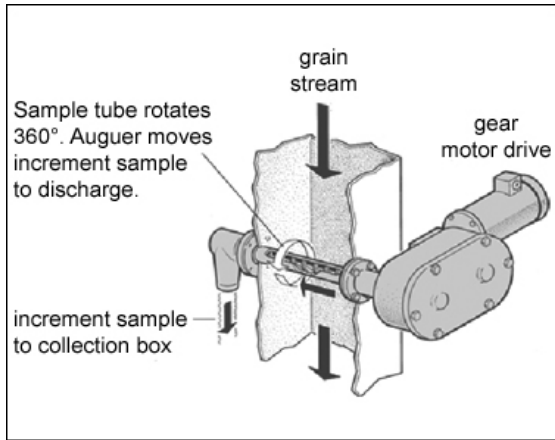

Point type sampler

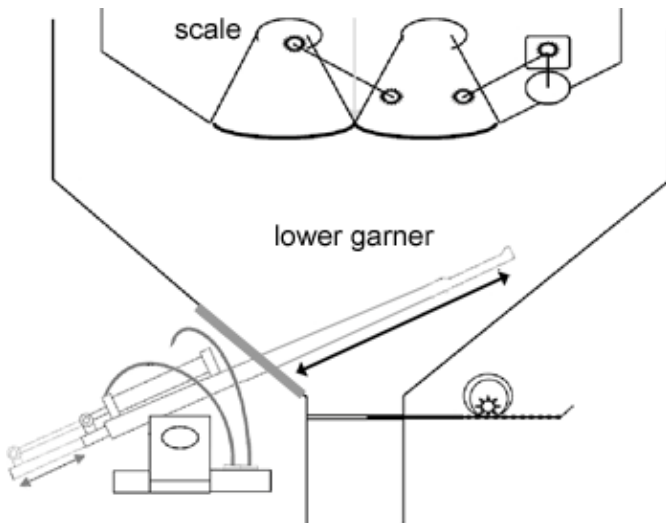

The line drawing shows a point type sampler. The sampling tube extends to at least 75% of the width of the grain stream.

Chapter 4

Manual sampling

4.1 Manual stream sampling

Samples taken from the grain stream must be drawn at regularly timed intervals from the beginning to the end of the transfer. Equipment that can be used for manual sampling under these conditions is described as follows:

Hand scoop

The hand scoop is a sampling device consisting of a rigid material scoop attached to a 50-100 centimetre handle which is stiff and durable. The sample collector capacity must be a minimum of 50 grams and not more than 200 grams.

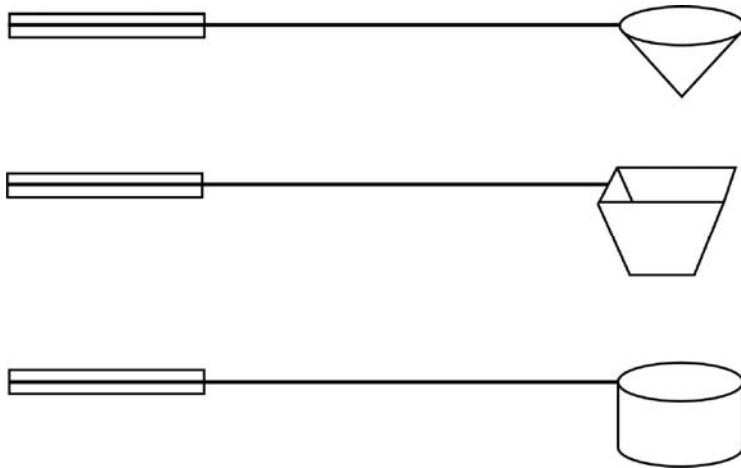

The line drawing shows 3 different hand scoops.

When manual stream sampling with a hand scoop off the top of a belt, insert the sampling tool into the stream at an alternate point across the stream (left, middle, right) for each sampling action. The scoop should be placed into the flow of product “upstream” and matching the belt speed, moved “downstream”, as the scoop is turned to fill with grain. Moving the scoop with the flow allows sampling of the appropriate location on the belt without splashing product or overflowing the scoop.

When manual stream sampling free-flowing product, the scoop should be placed in to the flow of product upside down, then rotated 180 degrees to fill, and then pulled out of the product flow.

4.11 Determining sampling frequency when stream sampling

Caution: Sampling must be done in an area where the entire grain stream is accessible. All safety precautions must be adhered to when attempting to sample from a grain stream or near a moving conveyor.

Stream sampling bulk grain into containers

The sampling frequency is determined by the how much time is needed to load the grain and the lot size. The CGC requires a minimum of 5 primary samples per 20 tonne container, collected systematically at evenly spaced timed intervals (at least one primary sample every 4 metric tonnes). If a larger composite sample is required, reduce the interval between primary sample collections throughout the entire loading process.

Example to determine sampling frequency:

The grain lot is 2 containers of 20 tonnes each and will be loaded in approximately 30 minutes.

40 tonnes total weight ÷ 4 (1 sample per 4 tonnes) = 10 samples minimum are required.

30 minutes to load the lot ÷ 10 required samples = 3 minutes.

A sample will be taken at timed intervals every 3 minutes throughout the entire loading of the 40 tonne lot.

The hand scoop that is being used in this example has a capacity of 200 grams.

10 scoop samples x 200 grams per scoop = 2000 gram sample will be collected for this lot.

Note: if a larger composite sample is required, the solution is to shorten the interval between samples, and not increasing the size of the scoop.

Stream sampling large bulk lots

Procedure:

1. The sampling frequency must be at least one primary sample selection per minute taken systematically throughout the entire transfer.
2. On commencement, insert the hand scoop into the grain stream at alternating points across the stream (left, middle, right). The scoop should be placed into the grain flow “upstream” and overturned. While moving “downstream”, the scoop is turned to fill grain. Moving the scoop with the grain flow allows sampling of the appropriate location in the grain stream without splashing grain or overflowing the scoop.
3. Examine the primary samples for uniformity while sampling.
4. Combine the primary samples in a sample container to form a composite sample.
5. Reduce the composite sample to the appropriate size using a boerner type divider (see Chapter 5).

4.2 Manual sampling static lots

Grain may be sampled when stored in bags or totes. Bags are considered to be grain sacks generally weighing 100 kg or less, totes are considered to be grain stored in sacks generally weighing 100 kg or more. The equipment used to sample grain stored in totes or bags is the double sleeved trier, or nobbe trier.



Left: grain storage totes; Right: stacked grain storage bags

Equipment - Double sleeve trier

The double sleeve trier consists of a hollow tube with a solid pointed end and a close fitting inner tube such that the product cannot slip between the two sleeves. The inner tube may be with or without partitions (fixed or removable plugs) between the slots.

Partitioned double sleeve triers may be used horizontally or vertically. Double sleeved triers without partitions may only be used vertically when sampling sacked grain weighing greater than 100 kg. Vertical sampling of sacked grain 100 kg or less must be undertaken with the partitions in place.



The illustration shows 3 different sizes of double sleeve triers.

Multiple openings (slots/holes) are cut into both the inner and outer tubes so that turning the inner tube aligns the openings of the inner and outer tubes. There is a greater risk of contamination with this type of trier. Care must be taken to ensure that all the openings in both the inner and outer tubes are clean and no small seeds or particles are lodged between the two tubes. When closing the openings there is a risk of damaging the product trapped between the edges of the slots but this damage can be reduced by closing the openings slowly to the point where resistance is felt.

The contents of the entire tube represent one primary sample. When sampling horizontally, the trier must be long enough to reach the opposite end of the bag. When sampling bags vertically (weighing 100 kg or less), a partitioned trier must be used and the trier must be long enough to reach the bottom of the container or bag. When vertically sampling bags weighing greater than 100 kg, the trier may be used with or without partitions. The tier must be long enough to reach the bottom of the bag or tote.

Equipment - Nobbe trier

The Nobbe trier is a pointed tube with an oval opening near the pointed end. It is relatively compact, making it easy to transport. The risk of contamination is low as the trier is easy to keep clean. A Nobbe trier is suitable for sampling free-flowing product in bags, but only where the trier can reach to the centre of the bag. It may only be used horizontally and its use is limited to penetrable containers.



The illustration shows three different sizes of Nobbe triers.

Note: Facilities bagging grain after cleaning and processing may sample with a hand scoop off the top of the bag (100 kg or less) once filled, and prior to closing provided the following conditions are met:

1. The same sampling tool is used to sample the entire lot.
2. The sampling tool is of sufficient size (within the range of 50 to 200 grams) to ensure that the composite is a minimum of 1000 grams.
3. The sampling of the lot is done at evenly spaced structured intervals at the intensity determined by the Table listed in section 4.26.

4.21 Approved triers by crop type for grain

CGC approved methods of manual sampling a static lot is done using a double sleeve trier or the nobbe trier. The sampling device should not select the product by size or damage the product being sampled. The appropriate trier is selected by crop type as described in the following chart.

Grain	Trier size
Barley	Large (20 mm or greater)
Beans	Large (20 mm or greater)
Buckwheat	Large (20 mm or greater)
Canola	Small (8 to 14 mm)
Chickpeas	Large (20 mm or greater)
Corn	Large (20 mm or greater)
Flaxseed	Medium (15 to 19 mm)
Lentils	Medium (15 to 19 mm)
Mixed grain	Large (20 mm or greater)
Mustard	Small (8 to 14 mm)
Oats	Large (20 mm or greater)
Peas	Large (20 mm or greater)
Rapeseed	Small (8 to 14 mm)
Rye	Large (20 mm or greater)
Safflower	Large (20 mm or greater)
Soybeans	Large (20 mm or greater)
Soybeans (natto type)	Medium (15 to 19 mm)
Sunflower	Large (20 mm or greater)
Triticale	Large (20 mm or greater)
Wheat, Amber Durum	Large (20 mm or greater)
Wheat	Medium (15 to 19 mm)

4.22 Requirements for probing sacked grain

Caution: Safety precautions must be adhered to while sampling stacked grain sacks.

1. Sacked grain refers to grain in any type of bag or tote.
2. The facility/requestor must provide personnel to move sacks as necessary.
3. All sacks in the lot must be accessible.
4. All sacks in the lot must be of the same product, weight value and identification.
5. All sacks must be tagged or stencilled with lot number/identification.

4.23 Procedure for sampling horizontally – double sleeve trier

1. Carefully insert the trier diagonally on the horizontal plane into the container in the closed position until it reaches the opposite corner of the container. The outer tube opening must be facing upward. Care should be taken not to push the trier through the opposite corner of the container.
2. Open the trier until the inner and outer openings are aligned, then agitate it slightly to allow the openings to fill.
3. Close the trier gently (to the point of resistance) and then withdraw.
4. Place each primary sample into a suitable clean container(s) (pan/pail) to allow for checking for uniformity.
5. If necessary, reduce the sample to the appropriate size using a boerner-type divider.

4.24 Procedure for sampling vertically – double sleeve trier

1. Insert the closed trier through the top of the container on an angle until it reaches the bottom of the container.
2. Turn the inner sleeve until the inner and outer openings align and agitate the trier slightly to allow the openings to fill.
3. Gently close the trier and withdraw.
4. Collect the sample on a clean, long piece of paper or into a clean container that is the same length as the trier. (When sampled using partitions <100 kg bags)
5. Collect the sample in a clean container. (When sampled without using partitions > 100 kg bags)
6. Check for uniformity with the primary samples already drawn before adding to the composite sample.
7. If necessary, reduce the sample to the appropriate size using a boerner-type divider.

Note: Training videos for these two procedures are available for viewing on the CGC website at:

<http://www.grainscanada.gc.ca/media-medias/bagsampling/video-hsdt-ehdt-eng.htm>
<http://www.grainscanada.gc.ca/media-medias/bagsampling/video-vsdt-evdt-eng.htm>

4.25 Procedure for sampling - Nobbe trier

1. Insert the trier gently into the centre of the bag with the trier opening facing downward and the trier tilted upwards at an angle of approximately 30 degrees to the horizontal.
2. When sampling from the end of a bag, the opening of the trier must reach the centre of the bag. Insert the trier as close to the bottom edge of the bag as possible (i.e. below stitching)
3. When sampling from the side, the opening of the trier must reach the opposite side of the bag. Insert the trier at the bottom edge of the bag such that the 30 degree angle is achieved.
4. Rotate the trier through 180 degrees, bringing the slot to face upwards.
5. Withdraw the trier with gentle agitation to help maintain an even flow of product into the collecting pail/bag.
6. The trier must not be agitated without withdrawing.
7. When sampling from the end, withdraw with decreasing speed so that the quantity of product obtained from successive locations increases progressively from the centre of the bag.
8. When sampling from the side, withdraw with a constant rate of speed.
9. Each primary sample must be placed into a suitable clean container/pan/pail/clear bag to allow for checking for uniformity.
10. Read just the bag fibres to close the gap by running the point of the trier across the hole a few times in opposite directions.

4.26 Determining sampling intensity for static lots (bags)

A composite sample must be a minimum of 1000 grams for submission to the CGC. However, if the sample is to be utilized for multiple purposes, care must be taken to ensure the composite sample is sufficient in size to accommodate all necessary requirements. The numbers of primary samples indicated in this chart (highlighted in yellow) are minimums. If required, additional primary samples may be taken to construct a larger representative composite sample. All primary samples are to be drawn randomly throughout the entire lot.

Item	Number of bags in lot	Minimum number of primary samples to be taken	Totes
1	1 - 20	All bags must be sampled	All totes must be sampled- minimum 2 primary samples per tote. (maximum 300 totes per lot)
2	21-1000	6% of all bags in the lot, but not less than 20 samples randomly selected throughout	
3	>1000	3% of all bags in the lot, but not less than 60 samples randomly selected throughout	

Up to the maximum lot size of 10 containers or 5000 bags per composite.

4.27 Sampling Intensities of Grain Stored in Totes

All totes must be sampled with a **minimum of two (2) primary samples per tote** (highlighted in yellow) whether stream sampling (see stream sampling procedure defined above) while the tote is being filled, or probed after the tote is full.

Item	Number of bags in lot	Minimum number of primary samples to be taken	Totes
1	1 - 20	All bags must be sampled	All totes must be sampled- minimum 2 primary samples per tote. (maximum 300 totes per lot)
2	21-1000	6% of all bags in the lot, but not less than 20 samples randomly selected throughout	
3	>1000	3% of all bags in the lot, but not less than 60 samples randomly selected throughout	

Totes are grain sacks generally weighing 100 kg or more.

1. All totes in the lot must be accessible and must be sampled.
2. The maximum number of totes in a lot or sub-lot is limited to 300.
3. Insert the closed probe into the tote to the maximum depth (bottom of the tote).
4. Open the probe and agitate slightly to fill the inner tube.
5. Close the probe slowly to the point where resistance is felt in order to minimize any damage to the sampled product.
6. Extract the probe and release the sample onto a cloth, trough or into a sample container and examine it for uniformity. Based on the quality and quantity of sample taken by the probe, determine if multiple probes are required. It is important to note that each tote in the lot must be sampled the same number of times to ensure equal representation within the lot.
7. A minimum of 2 probes per tote is required.
8. If necessary, reduce the composite sample to the appropriate size using the boerner divider.

Note: Totes may be sampled as they are being filled using the procedure outlined for manual stream sampling as defined in section 4.1 of this Guide. A minimum of two primary samples for each tote must be taken while being filled, at evenly spaced intervals. For example, one primary sample would be taken at the midway point, and one taken at completion.

Chapter 5

CGC Approved Sample Dividing Equipment

A Boerner-type divider is the only divider approved for use by the CGC. It is a gravity-operated dividing apparatus that reduces a grain sample to smaller equal portions. The sample is placed in the upper hopper and released by opening the valve located in the hopper throat. The sample flows downward and is evenly dispersed over a cone with evenly spaced separations. The divided sample is rejoined in two grain streams which empty into two collecting pans at the bottom.

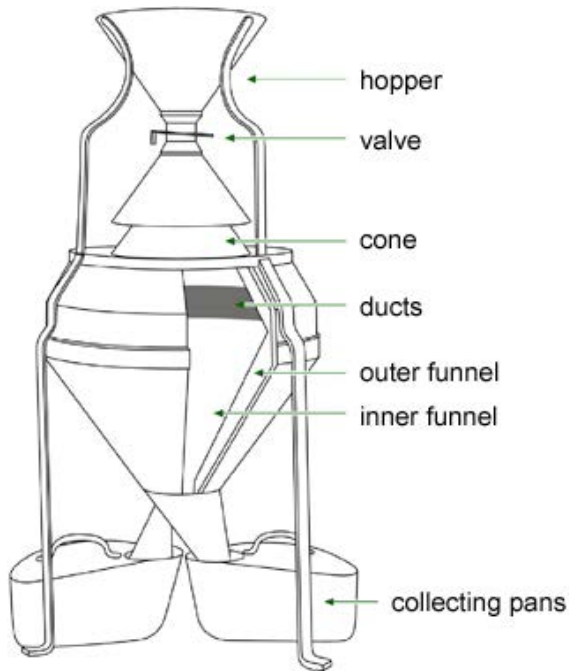

Boerner-type divider

Procedure for dividing a sample using the Boerner-type divider:

1. Clean the divider and the collection pans.
2. Close the valve at the bottom of the hopper and place a collecting pan under each of the two outlets.
3. Pour the grain into the hopper.
4. Open the valve quickly. The grain will fall by gravity over the cone where it will be evenly distributed through the channels and spaces. The grain is divided into two halves, with each part being collected in one of the two collecting pans.
5. To mix the grain, take the collecting pans and repeat steps 2 to 4 at least once for free-flowing grain and at least twice for chaffy grain.
6. For sample reduction, repeat steps 2 to 4. This will result in about one-half of the sample in each collecting pan.
7. If smaller sub-samples are required, repeat steps 2 to 4 with the content of one of the collecting pans – always use the collecting pan from the same side.

Chapter 6

Contact information

Please direct any comments, questions or concerns regarding the content of this manual or any proposed revisions or suggestions to:

<p>Randy Dennis Chief Grain Inspector for Canada Canadian Grain Commission 900-303 Main Street Winnipeg, Manitoba R3C 3G8 Telephone: 204-983-2780 Fax: 204-983-7550 Email: randy.dennis@grainscanada.gc.ca</p>	<p>Laurie Campbell Program Manager, National Monitoring Unit Canadian Grain Commission 1056 Pembina Highway Winnipeg, Manitoba R3T 1Z8 Telephone: 204-461-3353 Fax: 204-984-5140 Email: laurie.campbell@grainscanada.gc.ca</p>
---	---