

# FAST DRYING OF DRY-CURED MEAT PRODUCTS: QUICK-DRY-SLICE (QDS) PROCESS TECHNOLOGY\*

Comaposada J., Arnau J., Garriga Margarita, Ferrini G., Xargayó Marta, Bernardo J., Corominas Montserrat, Gou P., Freixanet, L., Lagares J., Monfort J. M.

*Abstract:* The traditional process for dry-cured meat products is time consuming. A Quick-Dry-Slice process based on a continuous system that combines both convective and vacuum drying could accelerate the drying of slices after the desired pH is reached in fermented sausages.

**Key words:** sausage, rapid, dehydration, fermentation, vacuum

## Brzo sušenje suvih i salamurenih proizvoda od mesa: tehnologija brzog sušenja odrezaka

*Sadržaj:* Tradicionalni proces sušenja i salamurenja proizvoda od mesa zahteva mnogo vremena. Proces brzog sušenja odrezaka zasnovan je na kontinualnom sistemu koji kombinuje sušenje konvekcijom i vakuum sušenje, a može da ubrza sušenje odrezaka nakon postizanja željenog pH u fermentisanim kobasicama.

**Ključne reči:** kobasica, brzo, dehidracija, fermentacija, vakuum

### Introduction

In the manufacture of dry-cured meat products by traditional methods, the drying stage is the most time consuming. In traditionally used drying methods this stage takes 1-2 weeks for small caliber fermented sausages, three to six weeks in the case of fermented sausages with higher diameter, and 1.5-3 years in Iberian dry-cured hams. During the fermentation process the pH drops, the pieces of meat bind and so facilitate the slicing process. During the drying phase, the product undergoes a dehydration process that is accompanied by a series of biochemical reactions produced by endogenous and microbial enzymes, which break down part of the lipids and proteins which gives the product its characteristic texture and flavor. In conventional dryers, dry air is injected by nozzles located in a series of perimeter conduits and the moist air is returned through a series of centrally mounted conduits located on the ceiling of the drying chamber. The design of these dryers causes the air passing over the meat products located next the nozzle exits to have different properties than the air passing over the products in other parts of the dryer.

The drying process is affected by the resistance of the meat to the flow of water and the distance that the water must travel until it reaches the surface of the product in order to be extracted (Crank, 1975). The objective of this study is the evaluation of a drying process for slices of meat products after fermentation, where the drying process consists of a convection phase followed by a vacuum drying phase (Quick-Dry-Slice process).

### Drying technology based on the "Quick-Dry-Slice process"

Quick-Dry-Slice (QDS) drying technology is based on the drying and maturing method for sliced products proposed by Comaposada *et al.*, 2004. In this technology, the sausages are fermented until they attain the desired pH, then frozen, sliced and dried following a convective drying stage and a subsequent vacuum drying stage. With this drying process it is possible to obtain the desired water content and texture in only 30 minutes (Figure 1).

\*Plenary paper on International 55<sup>th</sup> Meat Industry Conference held from June 15-17<sup>th</sup> 2009 on Tara mauntain

\*Plenarno predavanje na Međunarodnom 55. savetovanju industrije mesa, održanom 15-17. juna 2009. na Tari

AUTHORS: Josep Comaposada, [josep.comaposada@irta.es](mailto:josep.comaposada@irta.es), Jacint Arnau, Margarita Garriga, Gabriele Ferrini, Pere Gou, Josep M<sup>o</sup> Monfort. IRTA, Finca Camps i Armet, E-17121 Monells, Girona, Spain; Marta Xargayó, Llorenç Freixanet, Josep Lagares. METALQUIMIA S.A., St. Ponç de la Barca, s/n, 17003 Girona, Spain; Jordi Bernardo, Montserrat Corominas. CASADEMONT S.A., Paratge Constantins, s/n, 17164 Bonmatí, Girona, Spain.

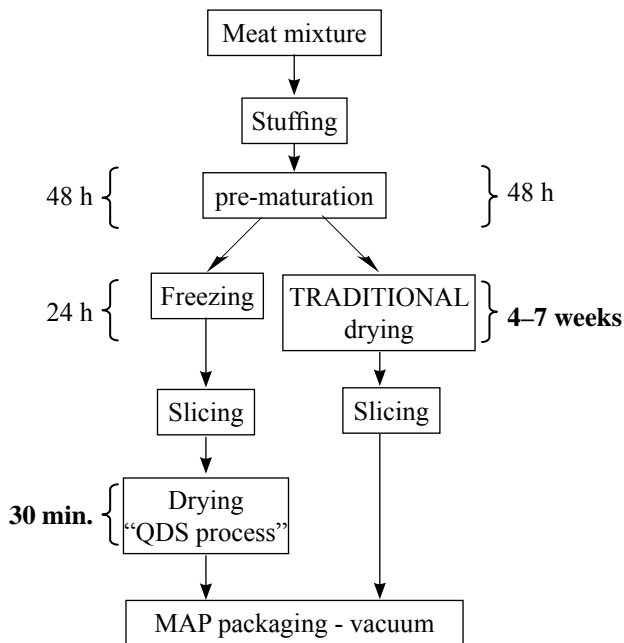

**Figure 1.** Time comparison between the traditional drying process and the process using QDS technology for drying dry-cured meat products with a diameter of approximately 80 mm.

**Slika 1.** Poređenje između tradicionalnog postupka sušenja i QDS tehnologije kod sušenja salamurenih proizvoda od mesa prečnika 80 mm

### The QDS system

The QDS system developed by Metalquimia S.A. (Figure 2) was designed according to a continuous production system. There is a charging zone for frozen slices, a tempering and pre-drying zone with air circulation, and a vacuum drying zone in which the required moisture is extracted from the slices. Finally, and depending on the exit temperature of the slices, the product is tempered again prior to being packaged in order to prevent condensation or adherence of fat to the packaging. The slices are placed on a stainless steel belt designed to facilitate the extraction of moisture from the slices, both during drying by convection and during the vacuum drying phase. The air used for drying and tempering during the forced convection stage is purified by means of a high efficiency particulate air (HEPA) filter in order to minimize contamination of the air coming into contact with the product. In addition, the speed of the tempering and drying processes can be adjusted by controlling the temperature, relative humidity and velocity of the air passing over the product. The vacuum drying stage is controlled mainly via the operating pressure and the heating temperature. The different stages of the processes are linked with one another by means of conveyor

belts and slice loading/unloading mechanisms. The complete process is controlled by a PLC which additionally enables monitoring and recording of the control parameters.

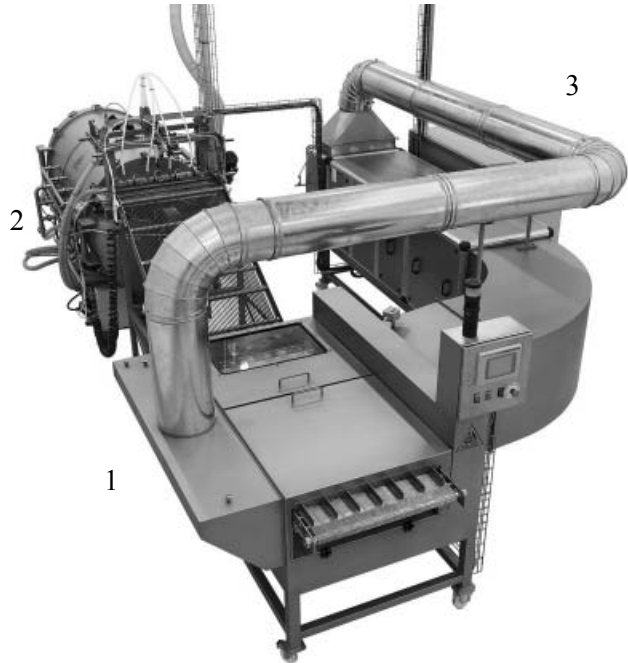

**Figure 2.** The QDS system: 1. Tempering and pre-drying section; 2. Vacuum drying section; 3. Air purification circuit with HEPA filter

**Slika 2.** QDS sistem: 1. temperiranje i faza predušenja; 2. faza vakuum sušenja; 3. sklop za prečišćavanje vazduha sa HEPA filterom

### Microbiological and sensory evaluation

A number of studies were carried out to compare the safety and the sensory properties of the dry-cured meat products produced by the traditional method with those produced by the QDS process. In these studies the microbiological quality of „salchichón” sausages was evaluated after determining the following parameters: bacterial counts of *Staphylococcus aureus*, sulfite-reducing clostridia, *Escherichia coli* and *Listeria monocytogenes*. In addition, the presence / absence of *Salmonella* was also investigated in 25 g samples. The study also included the pH measurement of the products at different sampling times, as well as the water activity of the final product.

The pH of the fermented sausages dried by the traditional method was lower than that of those dried by means of the QDS process (Table 1). Moreover, an additional reduction of pH was observed in fermented sausages stored at 13°C, an effect that was not found at 1°C.

**Table 1.** Average losses obtained for the different drying processes and pH of fermented sausages at different sampling times**Tabela 1.** Prosečan kalo dobijen za različite procese sušenja i pH za fermentisane kobasice pri različitim vremenima uzorkovanja

Drying process	Batch	Diam.	Drying time / days	Drying losses %	a <sub>w</sub> End of drying	pH			
						Before drying	End of drying	3 month storage	
								1°C	13°C
Traditional	1	80	38	28.6	0.907	5.32	4.89	5.00	4.70
	2	80	38	26.5	0.917	5.21	4.85	4.99	4.63
QDS	1	80	<1	30.7	0.902	5.32	5.25	5.14	4.99
	2	80	<1	32.8	0.887	5.21	5.15	5.20	5.15

The results of the microbiological analyses and the *Staphylococcus aureus*, sulfite-reducing clostridia and *Escherichia coli* counts for each sampling time are shown in Tables 2, 3 and 4, respectively. The results show that both drying processes (tra-

ditional and QDS), as well as the subsequent storage of the vacuum-packed slices of „salchichón“ sausage, achieve similar results in terms of reducing the number of microorganisms below the detection limit.

**Table 2.** *Staphylococcus aureus* (log cfu/g) counts in fermented sausages depending on the drying process**Tabela 2.** Broj *Staphylococcus aureus* (log cfu/g) u fermentisanim kobasicama u zavisnosti od procesa sušenja

Drying process	Batch	Before drying	End of drying	Storage		
				15 days 4°C	3 months 1°C	3 months 13°C
Traditional	1	1.94	<1.00	<1.00	1.10	<1.00
	2	2.26	1.03	<1.00	<1.00	<1.00
QDS	1	1.94	1.77	<1.00	<1.00	<1.00
	2	2.26	1.91	1.27	<1.00	1.10

**Table 3.** Sulfite-reducing clostridia (log cfu/g) counts in fermented sausages depending on the drying process.**Tabela 3.** Broj sulfitoredukujućih klostridija (log cfu/g) u fermentisanim kobasicama u zavisnosti od procesa sušenja

Drying process	Batch	Before drying	End of drying	Storage		
				15 days 4°C	3 months 1°C	3 months 13°C
Traditional	1	1.22	<1.00	<1.00	<1.00	<1.00
	2	1.46	<1.00	<1.00	<1.00	<1.00
QDS	1	1.22	<1.00	<1.00	<1.00	<1.00
	2	1.46	1.09	<1.00	<1.00	<1.00

**Table 4.** *Escherichia coli* (log cfu/g) counts in fermented sausages depending on the drying process**Tabela 4.** Broj *Escherichia coli* (log cfu/g) u fermentisanim kobasicama u zavisnosti od procesa sušenja

Drying process	Batch	Before drying	End of drying	Storage		
				15 days 4°C	3 months 1°C	3 months 13°C
Traditional	1	3.45	1.76	1.43	<1.00	<1.00
	2	3.45	1.86	1.62	<1.00	<1.00
QDS	1	3.45	2.97	1.47	<1.00	<1.00
	2	3.45	2.89	1.22	<1.00	<1.00

As to the prevalence of *Salmonella* in the fermented sausages, it was observed that in the case of a raw material contaminated with this pathogen (presence in 25 g) prior to drying, the presence of *Salmonella* could still be detected in the 25 g sample of the final product, regardless of the process followed (traditional or QDS). The studies carried out by Smith *et al.*, (1975a, 1975b) report the incidence of dry-cured meat products showing the presence of *Salmonella* in those cases where the traditional drying method was used. The study concludes that in the cases where the pathogen is present after the pre-maturation stage, it is difficult to guarantee its absence in the final product by the reduction of the water activity which takes place during the drying process. In view of these problems and in compliance with the Commission Regulation (EC) No. 2073/2005 on microbiological criteria for foodstuffs, which requires the absence of *Salmonella* in a 25 g sample for these types of products, the QDS process facilitates the integration of elements that inactivate this microorganism and could therefore improve the safety of the dry-cured meat product. To evaluate this possibility, a very low dose (<3 NMP/g) of *Salmonella* was inoculated and 2 g/kg of sodium acetate were added to the mixture to be processed by the QDS method. The QDS process showed better results (greater number of 25 g samples showing an absence of the pathogen) than the conventional process (Garriga *et al.*, unpublished results). These preliminary results will be validated in future investigations.

The *Listeria monocytogenes* counts, carried out in all the fermented sausages analyzed, were all below the detection limit (<20 cfu/g) for all the sampling times (end of pre-maturation, end of dry-

ing and storage). It can hence be concluded that, starting from raw materials having low counts of the pathogen in question, it is possible to produce safe dry-cured meat products in compliance with the Commission Regulation (EC) No. 2073/2005 on microbiological criteria for foodstuffs, which limits the *L. monocytogenes* counts to <100 cfu/g for this type of products.

In order to further investigate the effects of QDS drying on raw materials contaminated with *L. monocytogenes*, an experiment was conducted in which the pathogen was inoculated under controlled conditions. In this experiment, the initial meat mass was first inoculated with a mixture of 5 different cultures of the pathogen, with counts in the order of  $3 \times 10^3$  cfu/g. It was then subjected to the fermentation and maturation/drying processes by both the traditional and the QDS methods. In both cases, similar reductions in the pathogen counts were achieved, which shows that the QDS process is an efficient process with respect to food safety.

It is important to emphasize that there are complementary technologies, such as those based on high pressures, which have provided satisfactory results in minimizing the risk when applied to sliced products (Garriga *et al.*, 2003). High pressure affects appearance texture and flavour (Fulladosa *et al.*, 2009). However, the effect is small at the water content at which fermented sausages are commercialized. Color parameter L\* increases when the water content increases, while a\* parameter decreases (Comaposada *et al.*, 2009). The effect of high pressure on colour parameters was more important at a higher water content and hardly apparent at a lower water content (Fig. 3).

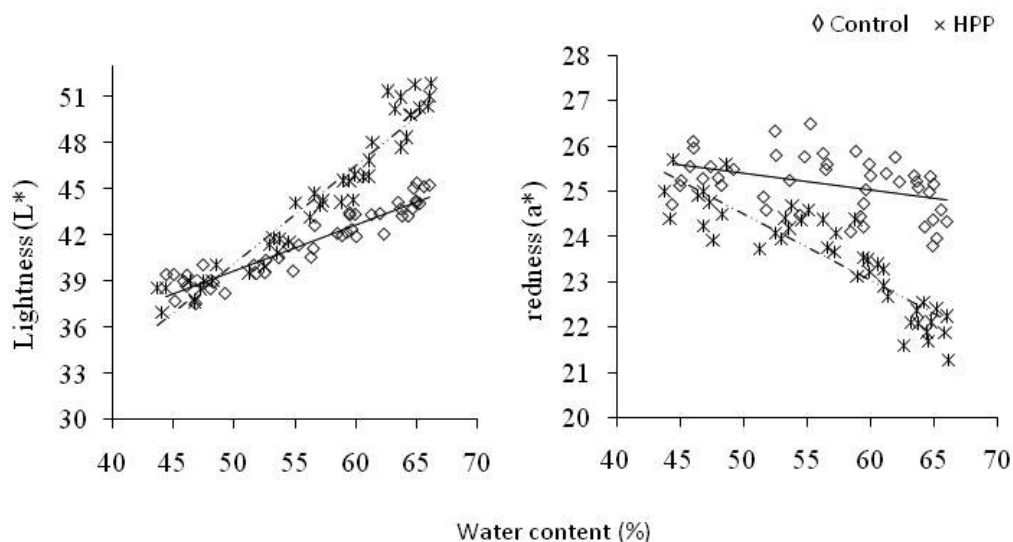

**Figure 3.** L\* and a\* color parameter depending on water content in dry-cured meat product with high pressure processing (7 min. at 500 MPa) and without (control)

**Slika 3.** L\* (svetlina) i a\* (stepen intenziteta crvene boje) u zavisnosti od sadržaja vode u suvim i salamurenim proizvodima od mesa proizvedenih pod visokim pritiskom (7 min. na 500 MPa) i bez visokog pritiska (kontrola)

With regard to the sensory evaluation, the slices of products made by the QDS process presented a less acidic aroma and taste than those made in the traditional manner (Table 5). This could be attributed to the lack of acidification during drying and the absence of an acidity gradient between the external and the internal parts of the slice. In addition, the volatile acids may have been partially eliminated during the drying stage. For this reason, in the QDS process, the pH may decrease to values below those of the conventional process during pre-maturation. The colour was also found to be more intense in the case of the QDS process because the intensity of the coloring agent Ponceau 4R was not reduced during the process. The flavor of the product produced by the traditional method was more balanced and it was therefore necessary to modify the initial mixture of spices and flavoring agents in the case of the QDS process in order to obtain equivalent products in both cases. Similarly, slight differences in appearance were found depending on the product. Figure 4 shows various products obtained by both methods after vacuum-packing.

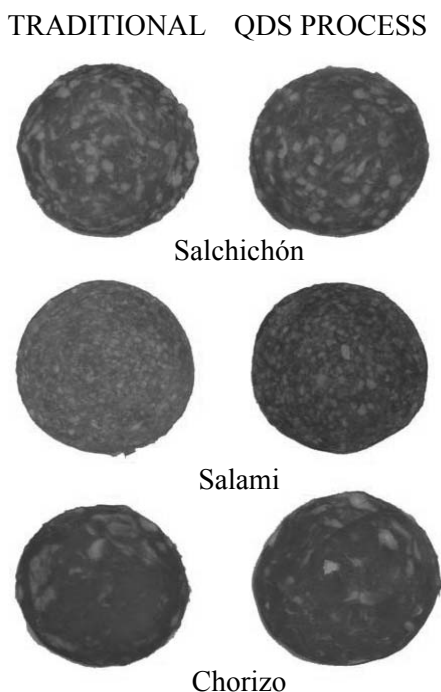

**Figure 4.** Visual comparison between “salchichón”, “salami” and “chorizo” sausages obtained by means of the traditional method and the QDS method after 7 days of storage in vacuum packs

**Slika 4.** Vizuelno poređenje između “salchichón”, “salami” i “chorizo” kobasica tradicionalnom metodom i QDS metodom nakon sedam dana skladištenja u vakuum pakovanju

**Table 5.** Evaluation of sensory parameters of “salchichón” sausage produced by the traditional method and by the QDS method

**Tabela 5.** Ocena senzornih parametara “salchichón” kobasice proizvedene tradicionalnim metodom i QDS metodom

	Drying process	
	Traditional	QDS
Roughness	0.21a	2.33b
Color	5.96a	6.67b
Flavor cured	6.00a	4.50b
Acidity	5.00a	1.00b

### Advantages of the QDS method and technological challenges

For the commercialization of dry-cured meat products in slices, QDS technology offers numerous advantages relative to conventional drying methods. There are advantages of a technological nature and others related to the operation and management of the production process. Among the technological advantages of the QDS process it is worth mentioning the ability to obtain more homogeneous products showing a less acidic flavour. Furthermore, the products are free from fungi and product safety control is enhanced thanks to a more precise monitoring of the process and of the product itself. In addition, the application of the QDS process results in increased productivity and decreased residues.

With regard to the production process, the QDS method offers enhanced production flexibility, an increase in speed, the possibility to implement just-in-time systems as well as requiring less space than conventional methods.

The QDS process may contribute to the development of new formats and products in line with the trends and lifestyles of today’s consumers, who demand ready-to-use products in a small format. It is also important to develop products aimed at especially sensitive consumer groups (people with high blood pressure, elderly people, immune-depressed patients, diabetics, obese people, etc.), as well as other types of products that will help to achieve the objectives set forth by the NAOS strategy, which was agreed between the Public Administration (represented by the Ministry of Health and Consumer Affairs, Ministry of Industry, Ministry of Education and Science), the Spanish Food Safety Authority (AESAs), the Spanish Food and Drinks Federation, (FIAB) together with large food producers and the majority of the Health Departments of the

Autonomous Communities of Spain, as an attempt to communicate the need to reduce the daily intake of fats and salt, among other things.

## **Acknowledgements**

This work was supported by the CDTI (Cenit Futural project) and the integrated projects within

the Sixth RTD Framework programme: Truefood (Traditional United Europe Food- Integrated Project FOOD-CT-2006-016264) and Q-Porkchains (Integrated Project FOOD-CT-2007-036245). The views expressed in this publication are the sole responsibility of the authors and do not necessarily reflect the views of the European Commission.

## **References**

- Comaposada, J., Arnau, J., Gou, P., Monfort, J. M., 2004.** Accelerated method for drying and maturing sliced food products, Patent WO/2005/092109;
- Comaposada, J., Ferrini, G., Arnau, J., Gou, P., 2009.** The effect of high pressure process on colour of dry-cured meat at different water content, The SAFE consortium 2<sup>nd</sup> International Congress on Food Safety, Girona, Spain;
- Crank, J., 1975.** The mathematics of diffusion, Oxford University Press, London;
- Fulladosa Elena, Serra, X., Gou, P., Arnau, J., 2009.** Effects of potassium lactate and high pressure on transglutaminase restructured dry-cured hams with reduced salt content, Meat Science, Volume 82, Issue 2 213-218;
- Garriga Margarita, Marcos Begoña, Aymerich Teresa, Hugas Marta, 2003.** Prospectiva de aplicación de altas presiones para la minimización de riesgos asociados a Salmonella y Listeria monocytogenes en embutidos madurados en frío, Eurocarne, 121, 93-99;
- Smith, J. L., Huhtanen, C. N., Kissinger, J. C., Palumbo, S. A., 1975a.** Survival of salmonellae during pepperoni manufacture, Appl. Environ. Microbiol. 30(5), 759-763;
- Smith, J. L., Palumbo, S. A., Kissinger, J. C., Huhtanen C. N., 1975 b.** Survival of Salmonellae dublin and Salmonella typhimurium in lebanon bologna, J. Milk Food Technol. 38(3), 150-154

Paper received: 10.04.2009.