



Tilapia fish microbial spoilage monitored by a single optical gas sensor

Ana T.S. Semeano ^{a,b}, Daniele F. Maffei ^c, Susana Palma ^b, Rosamaria W.C. Li ^a,
Bernadette D.G.M. Franco ^c, Ana C.A. Roque ^{b,*}, Jonas Gruber ^{a,**}

^a Departamento de Química Fundamental, Instituto de Química da Universidade de São Paulo, Av. Prof. Lineu Prestes, 748, CEP 05508-000 São Paulo, SP, Brazil

^b UCIBIO, Departamento de Química, Faculdade de Ciências e Tecnologia, Universidade Nova de Lisboa, 2829-516 Caparica, Portugal

^c Food Research Center, Departamento de Alimentos e Nutrição Experimental, Faculdade de Ciências Farmacêuticas, Universidade de São Paulo, Av. Prof. Lineu Prestes, 580, 05508-000, Sao Paulo, SP, Brazil

ARTICLE INFO

Article history:

Received 9 December 2017

Received in revised form

23 January 2018

Accepted 25 January 2018

Available online 3 February 2018

Keywords:

Gas sensor

Electronic nose

Fish freshness

Microbial spoilage

Optical sensor

Liquid crystal

ABSTRACT

As consumption of fish and fish-based foods increases, non-destructive monitoring of fish freshness also becomes more prominent. Fish products are very perishable and prone to microbiological growth, not always easily detected by organoleptic evaluation. The analysis of the headspace of fish specimens through gas sensing is an interesting approach to monitor fish freshness. Here we report a gas sensing method for monitoring *Tilapia* fish spoilage based on the application of a single gas sensitive gel material coupled to an optical electronic nose. The optical signals of the sensor and the extent of bacterial growth were followed over time, and results indicated good correlation between the two determinations, which suggests the potential application of this simple and low cost system for *Tilapia* fish freshness monitoring.

© 2018 The Author(s). Published by Elsevier Ltd. This is an open access article under the CC BY-NC-ND license (<http://creativecommons.org/licenses/by-nc-nd/4.0/>).

1. Introduction

Consumption of fish and fish-based products is in increasing demand due to the associated health-benefits. However, fish products are extremely perishable and sensitive to microbial growth, and the risks associated with the consumption of seafood containing harmful bacterial contaminants are not negligible (Erkmen & Bozoglu, 2016). Bacterial growth also causes spoilage, leading to formation of off-odors and off-flavors. Spoilage is typically detected when microbial counts are above 10^6 – 10^7 CFU/g (Gram & Dalgaard, 2002; Sugawara & Nikaido, 2014). The microbial contamination of fish can occur in the environment or during handling, processing, transport and storage. Fish freshness is assessed by organoleptic evaluation based on the determination of changes of color, odor and texture, together with the implementation of several grading systems, namely the Torry scheme and the quality index methods (Efremenko & Mirsky, 2017). In addition to bacterial counts for quality control, other indicators of

microbial activity in fish and fish products can be used, namely the assessment of total volatile basic amines (TVB-N; ammonia, di- and trimethylamine) or biogenic amines (putrescine, cadaverine), or the profiling of nucleotide catabolites. A common disadvantage of these methods is the fact that they are destructive, time-consuming and laborious, and require specialized equipment and skilled technicians for execution (Chang, Chuang, & Zan, 2017).

Considering that fresh fish has a very short shelf life, it is important to develop fast, easy to use non-destructive tools for real-time monitoring of fish freshness, applicable at any point of the production and supply chains. Conventional microbiological methods in foods can be very cumbersome and usually take at least 48 h to deliver a result regarding counts of viable bacterial contaminants. More recently, a number of faster automated methods have been developed, but most of them still depend in expensive and sophisticated machinery and well trained microbiologists (Jasson, Jacxsens, Luning, Rajkovic, & Uyttendaele, 2010; Law, Mutalib, Chan, & Lee, 2014). In this context, gas sensing is an appealing alternative due to its non-invasive and non-destructive nature, and the potential to provide very fast results. Among the several technologies used in gas sensing, including electronic noses, metal-oxide sensors arrays are by-far the most studied gas sensitive materials (Loutfi, Coradeschi, Mani, Shankar, & Rayappan, 2015).

* Corresponding author.

** Corresponding author.

E-mail addresses: cecilia.roque@fct.unl.pt (A.C.A. Roque), jogruber@iq.usp.br (J. Gruber).

Their major drawbacks are related with the high operating temperatures, humidity interference, high power consumption, low selectivity and sensitivity, limited stability and sensor ageing (Chen, Wang, & Choi, 2013; Lin, Jang, & Suslick, 2011), which has been triggering the development of alternative methods (Chung, Le, Tran, & Nguyen, 2017).

We have recently described multicomponent gels using liquid crystals as optical dopants, as tunable and robust gas sensitive materials which operate at ambient conditions, perfectly adaptable to the control of perishable food items as fish (Hussain et al., 2017). In the present work, we show that a single gel sensor, used in an in-house designed gas sensing device, can monitor in real time the deterioration of *Tilapia* fish. The changes observed in the optical signal given by the gas sensor, when exposed to the headspace of fish samples stored at ambient conditions, were correlated with the counts of mesophilic bacteria along time. The *Tilapia* fish (*Oreochromis niloticus*) was selected for this study due to its economic relevance. It is a freshwater fish raised worldwide in commercial aquaculture systems with a yearly production exceeding 2 million tons. In the past, only few attempts to monitor *Tilapia* fish deterioration by gas sensing used commercial electronic noses composed by arrays of metal-oxide sensors consisting of 12–16 sensors (Dodd, Hale, & Blanchard, 2004; Korel, Luzuriaga, & Balaban, 2001). The scarcity of data reinforces the impact of our proposed system which uses a low cost single optical gas sensor and operates at mild and ambient conditions with minimal power requirements (<100 mW).

2. Materials and methods

2.1. Chemicals

The biopolymer gelatin (from bovine skin, gel strength ~225 g

Bloom, type B) and the liquid crystal 4-cyano-4'-pentybiphenyl (5CB) (98%) were purchased from Sigma Aldrich. The ionic liquid 1-butyl-3-methylimidazolium dicyanamide ([BMIM][DCA], >98%) was purchased from IoLiTec (Germany).

2.2. Preparation and characterization of the optical sensor

The hybrid gel composed of gelatin, [BMIM][DCA] and 5CB was prepared as described in Hussain et al., 2017. The mixture was spincoated (1000 rpm, 30 s) onto a clean glass slide (20 mm × 10 mm) forming a uniform transparent film with a mean thickness of approximately 36 μm. The glass slide was placed in the light path of a white 5 mm light emitting diode (LED, Microtivity IL051) and a 5 mm light dependent resistor (LDR, Advanced Photonix NSL19-M51). Two crossed polarizing films were placed one in front of the LED and the other one in front of the LDR (Fig. 1).

A polarizing optical microscope (Olympus CX41) equipped with an Olympus SC30 camera was used to characterize the optical behaviour of the droplets in the hybrid gel films. Observations were performed in the transmission mode, with crossed polarizers (at 90°). Scanning electron microscopy (SEM) observations were conducted on a Carl Zeiss AURIGA CrossBeam (FIB-SEM) workstation coupled with energy dispersive X-ray spectroscopy (EDS). The dried hybrid gel materials were previously coated with an Au/Pd conductive film to avoid charge effects. Atomic force microscopy (AFM) measurements were conducted in an Asylum Research MFP-3D Standalone AFM system operated in alternate contact mode using commercially available silicon probes (Olympus AC240TS) with a resonance frequency of 70 kHz and a spring constant of 2 N m⁻¹. Images were processed with Gwyddion software after being plane-fitted/leveled.

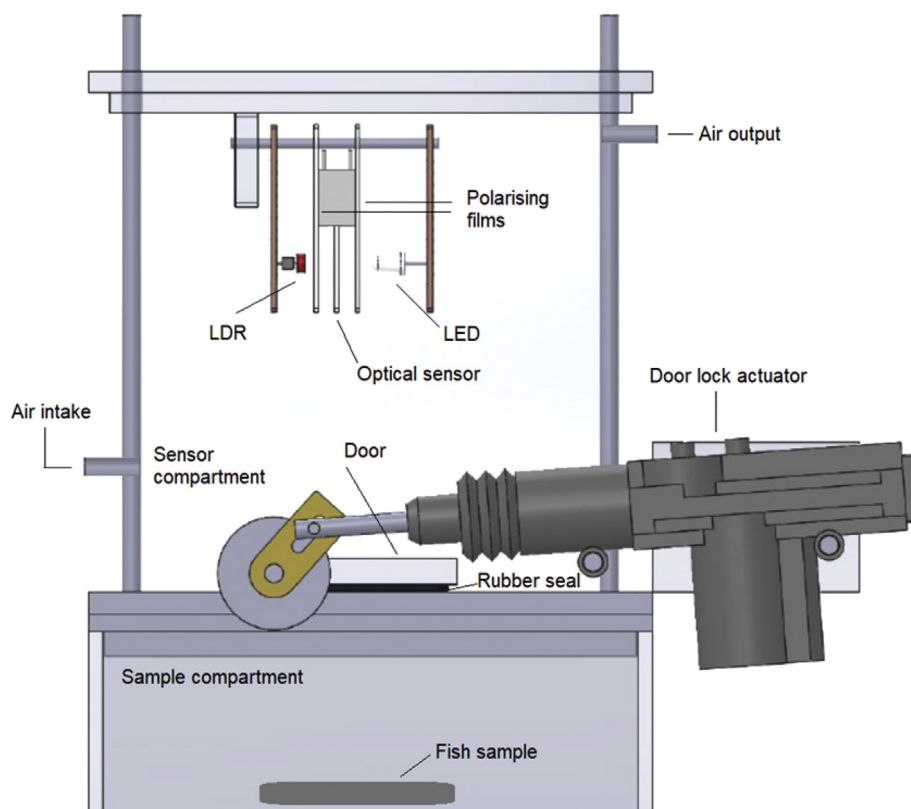

Fig. 1. Schematic representation of the gas-sensing device.

2.3. Gas sensor device

A system was built consisting of two closed compartments (one for the sensor and one for the fish samples) separated by a door controlled by a personal computer, as shown in Fig. 1 and Fig. S2. This system allowed alternate periods of exposure (to the volatiles of the sample) and recovery (to fresh air) of the sensor through the opening and closing of the door, mechanically coupled to an electromagnetic device (universal car power door lock actuator). For details about the circuitry see Supplementary Information (Fig. S3).

2.4. Monitoring *Tilapia* fish deterioration with gas sensor device

A 25 g slice of fresh fish (*Tilapia*, purchased at a Carrefour supermarket in São Paulo) was placed in the lower compartment of the device (Fig. 1). Each sampling cycle lasted 20 min: 5 min exposure to the volatiles emitted by the fish, followed by 15 min of recovery period in which clean ambient air passed through the sensor's chamber. The fish was maintained at 20 ± 1 °C throughout the test. The LED was fed with a 10 mA constant current. The LDR conductance was continuously monitored with a conductivity meter (Rocha, Gutz, & Lago, 1997) and transferred to a personal computer via a 10-bit analog-to-digital converter at a rate of one reading every 30 s. For details about the circuitry see Supplementary Information (Fig. S1). Conductance signals generated by the optical sensor as a response to the exposure to the fish headspace chamber were plotted as a function of time and the relative amplitudes (R_A) of the conductance peaks were determined using equation (1)

$$R_A = (G_2 - G_1)/G_1 \quad (1)$$

where G_1 and G_2 are the conductance values at the start of an exposure period and at the peak of the response, respectively.

2.5. Monitoring *Tilapia* fish deterioration by microbiological assays

Seven pieces of *Tilapia*, stored under the conditions described in 2.4, were submitted to enumeration of mesophilic aerobic bacteria using the aerobic plate count method recommended by the American Public Health Association (Morton, 2001). The counts were performed at time zero and after 2, 4, 6, 8, 10 and 12 h of storage at 20 ± 1 °C. Briefly, each sample (25 g) was transferred to a sterile plastic bag and homogenized with 225 mL of 0.1% peptone water (Oxoid, England) in a Stomacher 400 Lab-blender (Seward Medical, London, England) for 1 min. Serial decimal dilutions were prepared in 0.1% peptone water and 1 mL aliquots were plated on Plate Count Agar (Oxoid, England), in duplicates, and incubated at 37 °C for 24 h. The colonies were enumerated and results were expressed as log CFU/g.

3. Results and discussion

3.1. Properties of the optical sensor

In the hybrid gel film, composed by gelatin, the ionic liquid [BMIM][DCA] and the liquid crystal 5CB, used as the optical sensor in the gas-sensing device, the gelatin works as an immobilization matrix where droplets of ionic liquid-liquid crystal are stabilized,

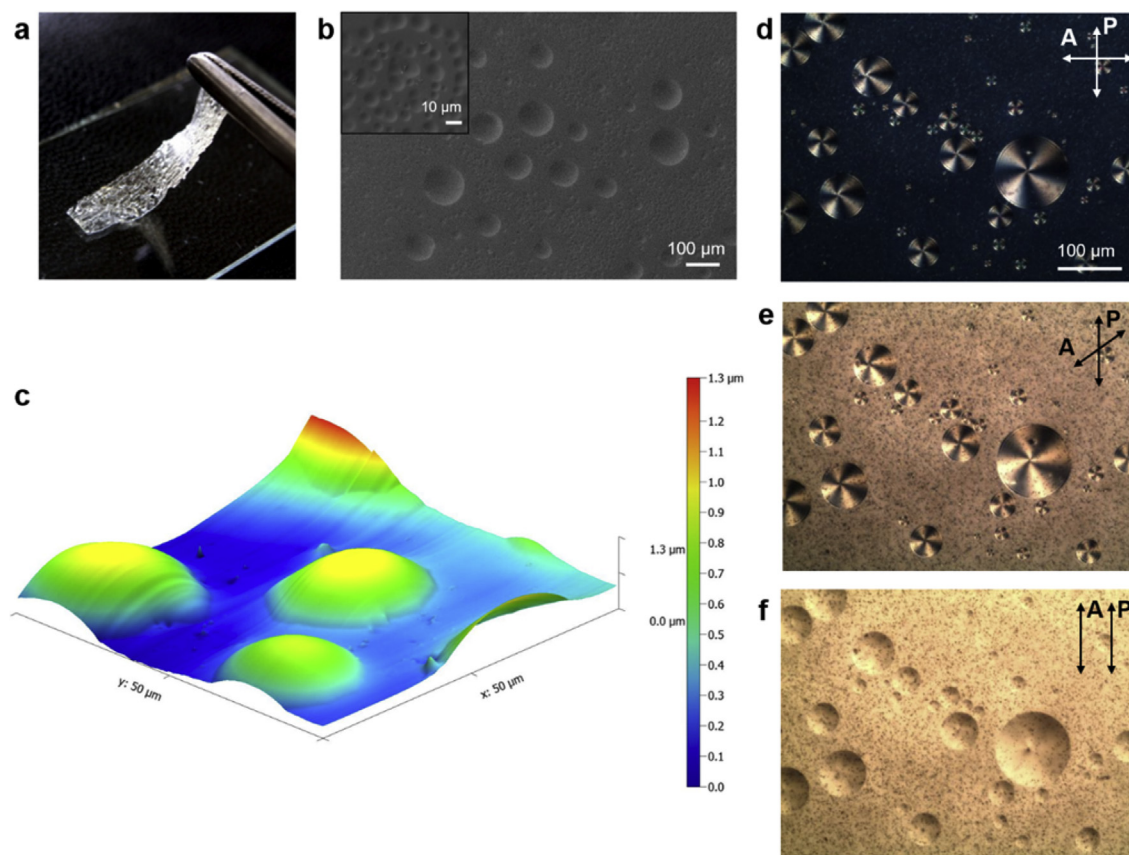

Fig. 2. Characterization of the gel film employed in the gas sensing device, composed by a mixture of gelatin, [BMIM][DCA], 5CB and water. **a**, Macroscopic image of the gel. **b**, Typical morphology of a gel film, by Scanning Electron Microscopy (SEM). **c**, Topological profile of the gel film, obtained by Atomic Force Microscopy (AFM). **d - f**, Polarizing Optical Microscopy (POM) images of the same field of view obtained with crossed (**d**), semi-crossed (**e**) and parallel (**f**) polarizers.

facilitating the use of the film as a gas sensitive material. The ionic liquid has a role on gelatin dissolution and also on the formation of liquid crystal droplets with radial configuration. The liquid crystal acts as an optical dopant, which reversibly changes its molecular order between the radial and isotropic states upon exposure to volatile organic compounds (VOCs) (Hussain et al., 2017). The gel used in this work formed a robust and self-sustained film that could be peeled off without fracturing. The characterization of the deposited film showed, as expected, the existence of protuberances with around 1 μm height, corresponding to droplets of ionic liquid-liquid crystal with an average droplet diameter of $50 \pm 30 \mu\text{m}$ ($n = 600$ samples) (Fig. 2).

3.2. Monitoring fish deterioration

The optical gas sensor responded to the presence of VOCs emitted by fish during the decay process, while the microbiological tests counted the colony forming units (CFUs) as a quantitative indication of the decay process. The assay was performed at room temperature, which is an accelerated test that simulates, in a smaller time scale, what happens when a fish is displayed for sale to the consumer in a refrigerated stand.

In the gas-sensing device, the optical properties of the sensor changed upon interaction with the VOCs produced by the fish samples. In particular, when observing Fig. 3a, it is clear that the light intensity measured by the LDR is higher before VOCs exposure, which indicates that the liquid crystal molecules are in a radial configuration. Upon VOCs exposure for 5 min, the light intensity decreases because the liquid crystal molecules within the ionic liquid-liquid crystal micelles alter their conformation to isotropic and polarised light cannot travel through the material. When the recovery stage occurs for 20 min, the light intensity measured by the LDR increases again, indicating the partial recovery of the liquid crystal supramolecular arrangement within the ionic liquid-liquid crystal droplets. In fact, it is observed that over the course of 12 h of VOCs exposure, the baseline optical signal decreases by 28%: until hour 6 the baseline decreases 12%, between hour 6–8 it maintains fairly constant, between the 8th and 11th hour it decreases further 16%, and from the 11th hour onwards it remains constant. This can be explained by the typical release of protic compounds (volatile amines) during fish microbial deterioration. It has been reported that the exposure of the hybrid gel films to vapours from protic solvents caused the dynamic rearrangement of ionic liquid-liquid crystal droplets into smaller units or the relocation within the matrix (Hussain et al., 2017).

The relative response (Ra) of the sensor over the 12 h of the accelerated fish deterioration experiment is shown in Fig. 3b. Until the 4th hour the relative response of the optical sensor remains constant, despite the decrease of the baseline; between the 4th and the 6th hour the relative response decreases 40%; between the 6th and 10th hour Ra values increases linearly 4.6 fold; but between hour 10th and 11th Ra decreases abruptly 80%, after which it remains constant.

The microbiological results are shown in Fig. 3c. Similarly to what was observed by the gas sensor, there was a decrease in mesophilic bacteria counts between the 4th and the 6th hour (~ 0.2 log CFU/g reduction), followed by an increase after that time, mainly between the 6th and 8th hour (from 5.8 to 6.7 log CFU/g). The decrease in microbial counts observed between the 4th and the 6th hour suggests competition of bacteria for nutrients, generating oscillations in the population density. Since microbial counts above 6–7 log CFU/g may indicate on-set spoilage of fish (Gram & Dalgaard, 2002; Sugawara & Nikaido, 2014), it is assumed that after the 8th hour the product may be considered unfit for consumption.

The results of the microbiological analysis were consistent with

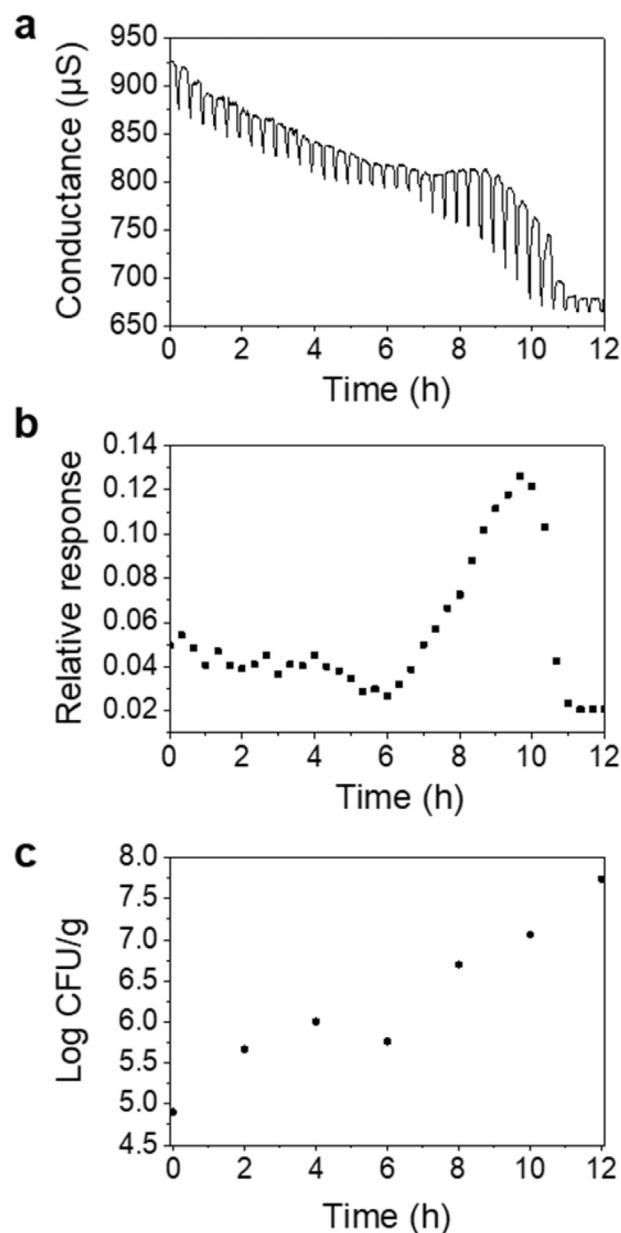

Fig. 3. Quality control of *Tilapia* fish during 12 h using the optical response of the gel film and the conventional microbiological counting method. **a**, Variation of the film's conductance while subjected to exposure and recovery of volatiles. **b**, Relative peak amplitudes of the conductance signal (relative optical response). **c**, Total counts of mesophilic bacteria (Log CFU/g).

the results obtained by the optical gas sensor. The increased relative response of the sensor paralleled the increase in bacterial counts in fish, suggesting that the sensor is detecting specifically the volatile compounds generated by the microorganisms that cause the fish to deteriorate. Prior studies have shown that these compounds are mainly short-chain alcohols and carbonyls, amines, sulphur compounds, aromatic, *N*-cyclic, and acid compounds (Alimelli et al., 2007). It is noteworthy that a single optical sensor was efficient in monitoring a perishable product, giving information on the quality of the fish. The overall time for a single sample analysis is only 3 min. This represents a significant improvement when looking at previous works monitoring *Tilapia* fish deterioration by gas sensing, where arrays of 12–16 metal-oxide sensors were needed with the associated higher burden in signal processing, analysis, and time (14 min) (Dodd et al., 2004; Korel et al., 2001).

4. Conclusions

The changes in the signals collected from the optical sensor based on the dynamical supramolecular arrangement of liquid crystal molecules were in line with the total counts of mesophilic bacteria in the tested fish samples, evidencing the potential application of this sensor for monitoring Tilapia fish deterioration. In particular, the largest change in the optical signal occurred exactly when the largest increase in bacterial counts was observed, and when it reached the limit to consider fish inappropriate for human consumption (above 6–7 log CFU/g). The decrease in the baseline of the optical signal indicates structural modifications in the sensing material, which may indicate the need to use it as a disposable component of the sensing device, which is a disadvantage attenuated by the low cost of the sensing film (0.15€ per optical sensor).

Acknowledgements

The authors acknowledge funding from Conselho Nacional de Desenvolvimento Científico e Tecnológico, Brazil (CNPq) through processes 400740/2014-1 and 306147/2016-5, from the European Research Council through the grant reference SCENT-ERC-2014-STG-639123 (2015–2020), the Unidade de Ciências Biomoleculares Aplicadas-UCIBIO, which is financed by national funds from FCT/MEC (UID/Multi/04378/2013) and co-financed by the ERDF under the PT2020 Partnership Agreement (POCI-01-0145-FEDER-007728). Franco and Maffei acknowledge São Paulo Research Foundation - FAPESP through Grants 2013/07914-8 and 2016/09601-5. Thanks are due to Mr. Norival Torregrossa Junior for drawing Fig. 1.

Appendix A. Supplementary data

Supplementary data related to this article can be found at <https://doi.org/10.1016/j.foodcont.2018.01.025>.

References

Alimelli, A., Pennazza, G., Santonico, M., Paolesse, R., Filippini, D., D'Amico, A., ... Di Natale, C. (2007). Fish freshness detection by a computer screen photoassisted

- based gas sensor array. *Analytica Chimica Acta*, 582(2), 320–328. <https://doi.org/10.1016/j.aca.2006.09.046>.
- Chang, L., Chuang, M., & Zan, H. (2017). One-minute fish freshness evaluation by testing the volatile amine gas with an ultra-sensitive porous-electrode-capped organic gas sensor system. *ACS Sensors*, 2(4), 531–539. <https://doi.org/10.1021/acssensors.6b00829>.
- Chen, S., Wang, Y., & Choi, S. (2013). Applications and technology of electronic nose for clinical diagnosis. *Open Journal of Applied Biosensor*, 2(2), 39–50. <https://doi.org/10.4236/ojab.2013.22005>.
- Chung, W. Y., Le, G. T., Tran, T. V., & Nguyen, N. H. (2017). Novel proximal fish freshness monitoring using batteryless smart sensor tag. *Sensors and Actuators B Chemical*, 248, 910–916. <https://doi.org/10.1016/j.snb.2017.01.134>.
- Dodd, T. H., Hale, S. A., & Blanchard, S. M. (2004). Electronic nose analysis of Tilapia storage. *Transactions of ASAE*, 47(1), 135–140.
- Efremenko, Y., & Mirsky, V. M. (2017). Virtual sensor array consisting of a single sensor element with variable affinity: An application for analysis of fish freshness. *Sensors and Actuators B Chemical*, 241, 652–657. <https://doi.org/10.1016/j.snb.2016.10.126>.
- Erkmen, O., & Bozoglu, T. (2016). Spoilage of fish and other seafoods. In *Food microbiology: Principles into practice* (pp. 301–306).
- Gram, L., & Dalgaard, P. (2002). Fish spoilage bacteria – problems and solutions. *Current Opinion in Biotechnology*, 13(3), 262–266.
- Hussain, A., Semeano, A. T. S., Palma, S. I. C. J., Pina, A. S., Almeida, J., Medrado, B. F., ... Roque, A. C. A. (2017). Tunable gas sensing gels by cooperative assembly. *Advanced Functional Materials*, 27(27), 1700803. <https://doi.org/10.1002/adfm.201700803>.
- Jasson, V., Jaccsens, L., Luning, P., Rajkovic, A., & Uyttendaele, M. (2010). Alternative microbial methods: An overview and selection criteria. *Food Microbiology*, 27(6), 710–730. <https://doi.org/10.1016/j.fm.2010.04.008>.
- Korel, F., Luzuriaga, D. A., & Balaban, M.Ö. (2001). Objective quality assessment of raw Tilapia (*Oreochromis niloticus*) fillets using electronic nose and machine vision. *Journal of Food Science*, 66(7), 1018–1024.
- Law, J. W. F., Mutalib, N. S. A., Chan, K. G., & Lee, L. H. (2014). Rapid methods for the detection of foodborne bacterial pathogens: Principles, applications, advantages and limitations. *Frontiers in Microbiology*, 5, 1–19. <https://doi.org/10.3389/fmicb.2014.00770>.
- Lin, H., Jang, M., & Suslick, K. S. (2011). Preoxidation for colorimetric sensor array detection of VOCs. *Journal of the American Chemical Society*, 133(42), 16786–16789. <https://doi.org/10.1021/ja207718t>.
- Loutfi, A., Coradeschi, S., Mani, G. K., Shankar, P., & Rayappan, J. B. B. (2015). Electronic noses for food quality: A review. *Journal of Food Engineering*, 144, 103–111. <https://doi.org/10.1016/j.jfoodeng.2014.07.019>.
- Morton, R. (2001). Aerobic plate count. In F. P. Downes, & K. Ito (Eds.), *Compendium of methods for the microbiological examination of foods* (4th ed., pp. 63–67). Washington, DC: American Public Health Association.
- Rocha, R. T., Gutz, I. G. R., & Lago, C. L. (1997). A low-cost and high-performance conductivity meter. *Journal of Chemical Education*, 74(5), 572–574.
- Sugawara, E., & Nikaido, H. (2014). Properties of AdeABC and AdeJK efflux systems of *Acinetobacter baumannii* compared with those of the AcrAB-TolC system of *Escherichia coli*. *Antimicrobial Agents and Chemotherapy*, 58(12), 7250–7257. <https://doi.org/10.1128/AAC.03728-14>.